

Catalog Number	B	C	Diameter(ΦA)	Cable capacity Cat 6/Cat 5e/Fiber Optic	Static Load(F)	Standard Box Quantity
ZQJH12	78.8[3.10]	22.0 [0.87]	3/4"	10/16/16	60LBS	50
ZQJH21	107.3 [4.22]	34.1 [1.34]	1-5/16"	30/50/50	60LBS	50
ZQJH32	118.0 [4.65]	35.0 [1.38]	2"	50/80/80	60LBS	50
ZQJH64	178.0 [7.01]	49.0 [1.93]	4"	185/300/300	60LBS	25
ZQJH96	178.0 [7.01]	49.0 [1.93]	6"	230/450/450	60LBS	25

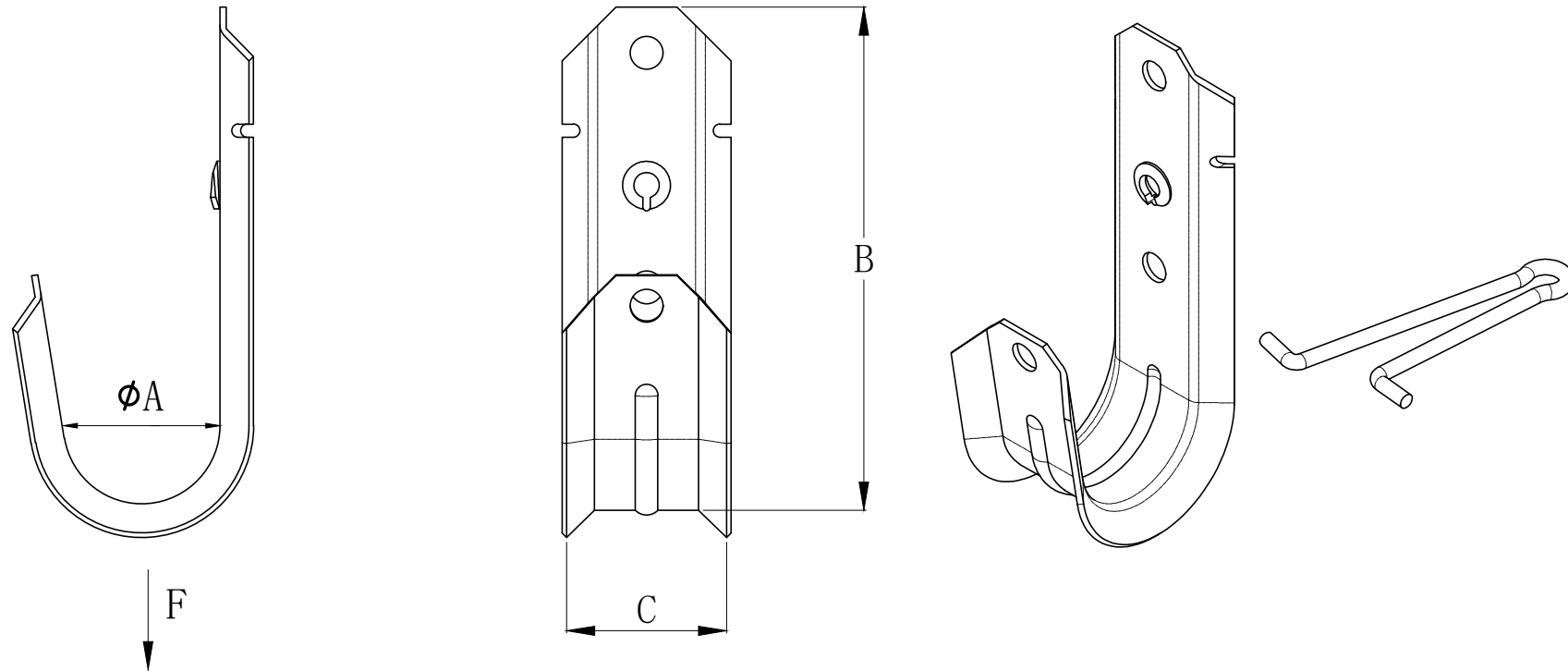

NOTES:

1. Material: Pre galvanized steel (G60) , Thickness: 1.35mm [0.053] .
2. Wire retainer available

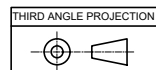

MATERIAL	Pre galvanized (G60)
FINISH	NO OIL

	NAME	DATE
DRAMN	YUAN	2022. 8. 17
CHECKED		
APPROVED (A)		
APPROVED (Customer)		

Hangzhou Zhiqi Electrical co.,Ltd
 Tel:86-571-82807601 Email: Linda@zhiqi-china.com

TITLE			
BASIC J HOOK			
SIZE	DWG NO.	REV	
A4	ZQJHxx		
SCALE: 1:1	PRINT DATE	REFERENCES	SHEET 1 OF 1

Catalog Number	B	C	ΦD	Diameter(ΦA)	Cable capacity Cat 6/Cat 5e/Fiber Optic	Static Load(F)	Standard Box Quantity
ZQJH12AC	78.8 [3.10]	22.0 [0.87]	1/4"	3/4"	10/16/16	60LBS	50
ZQJH21AC	107.3 [4.22]	34.1 [1.34]	1/4"	1-5/16"	30/50/50	60LBS	50
ZQJH32AC	118.0 [4.65]	35.0 [1.38]	1/4"	2"	50/80/80	60LBS	50
ZQJH64AC	178.0 [7.01]	49.0 [1.93]	1/4"	4"	185/300/300	60LBS	25
ZQJH96AC	178.0 [7.01]	49.0 [1.93]	1/4"	6"	230/450/450	60LBS	25

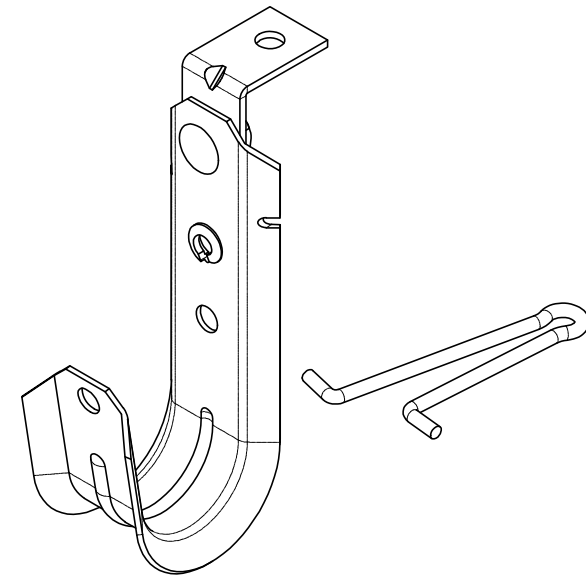
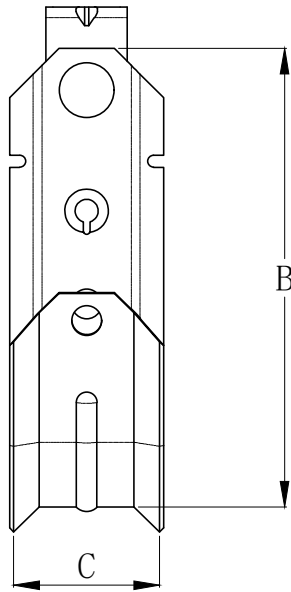
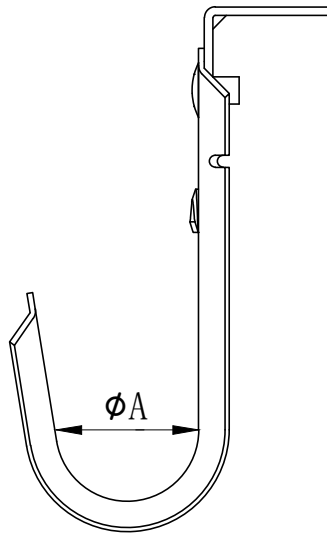
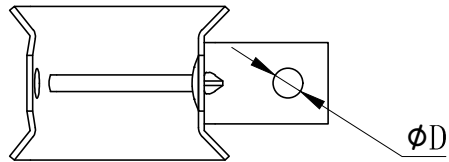

NOTES:

1. Material: J HOOK: Pre galvanized steel (G60) , Thickness: 1.35mm [0.053] .
Angle Bracket: Pre galvanized steel (G60) , Thickness: 2.0mm [0.079];
2. Wire retainer available

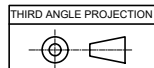

MATERIAL	Pre galvanized (G60)
FINISH	NO OIL

	NAME	DATE
DRAMN	YUAN	2022. 8. 17
CHECKED		
APPROVED (A)		
APPROVED (Customer)		

Hangzhou Zhiqi Electrical co.,Ltd
 Tel:86-571-82807601 Email: Linda@zhiqi-china.com

TITLE		
J HOOK WITH 90 DEG ANGLE CLIP		

SIZE	DWG NO.	REV
A4	ZQJHxxAC	
SCALE: 1:1	PRINT DATE	REFERENCES
		SHEET 1 OF 1

Catalog Number	B	C	Diameter(Φ A)	Flange Thickness (FT)	Cable capacity Cat 6/Cat 5e/Fiber Optic	Static Load(F)	Standard Box Quantity
ZQJH12ACM24	78.8[3.10]	22.0 [0.87]	3/4"	1/8"~1/4"	10/16/16	60LBS	50
ZQJH12ACM58	78.8[3.10]	22.0 [0.87]	3/4"	5/16"~1/2"	10/16/16	60LBS	50
ZQJH12ACM912	78.8[3.10]	22.0 [0.87]	3/4"	9/16"~3/4"	10/16/16	60LBS	50
ZQJH21ACM24	107.3 [4.22]	34.1 [1.34]	1-5/16"	1/8"~1/4"	30/50/50	60LBS	50
ZQJH21ACM58	107.3 [4.22]	34.1 [1.34]	1-5/16"	5/16"~1/2"	30/50/50	60LBS	50
ZQJH21ACM912	107.3 [4.22]	34.1 [1.34]	1-5/16"	9/16"~3/4"	30/50/50	60LBS	50
ZQJH32ACM24	118.0 [4.65]	35.0 [1.38]	2"	1/8"~1/4"	50/80/80	60LBS	50
ZQJH32ACM58	118.0 [4.65]	35.0 [1.38]	2"	5/16"~1/2"	50/80/80	60LBS	50
ZQJH32ACM912	118.0 [4.65]	35.0 [1.38]	2"	9/16"~3/4"	50/80/80	60LBS	50
ZQJH64ACM24	178.0 [7.01]	49.0 [1.93]	4"	1/8"~1/4"	185/300/300	60LBS	25
ZQJH64ACM58	178.0 [7.01]	49.0 [1.93]	4"	5/16"~1/2"	185/300/300	60LBS	25
ZQJH64ACM912	178.0 [7.01]	49.0 [1.93]	4"	9/16"~3/4"	185/300/300	60LBS	25
ZQJH96ACM24	178.0 [7.01]	49.0 [1.93]	6"	1/8"~1/4"	230/450/450	60LBS	25
ZQJH96ACM58	178.0 [7.01]	49.0 [1.93]	6"	5/16"~1/2"	230/450/450	60LBS	25
ZQJH96ACM912	178.0 [7.01]	49.0 [1.93]	6"	9/16"~3/4"	230/450/450	60LBS	25

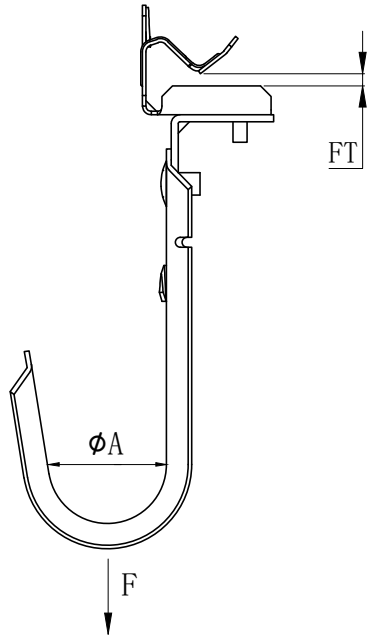
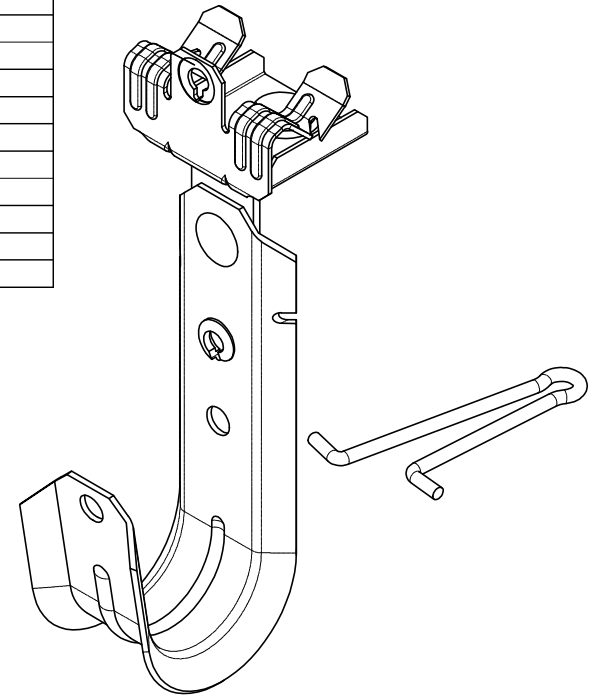

FT

F

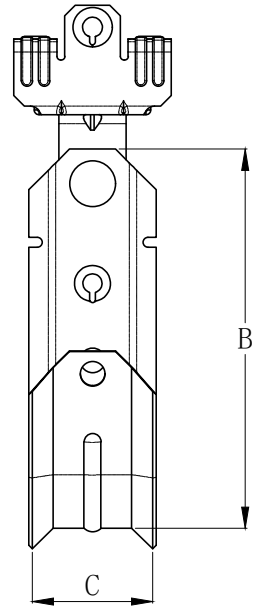

B

C

NOTES:

- Material: J HOOK: Pre galvanized steel (G60) , Thickness: 1.35mm [0.053] .
 Angle Bracket: Pre galvanized steel (G60) , Thickness: 2.0mm [0.079].
 Beam Clamp: C1065 steel , Thickness: 1.20mm [0.047].Finish: Black E-coating
- Wire retainer available

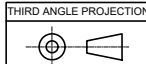

TOLERANCES UNLESS OTHERWISE SPECIFIED		NAME	DATE	Hangzhou Zhiqi Electrical co.,Ltd Tel:86-571-82807601 Email: Linda@zhiqi-china.com
INCHES	MILLIMETER	YUAN	2022. 8. 17	
ANGULAR:	ANGULAR:			
X.X: ±0.1	X: ±2.54			
X.XX: ±0.05	X.X: ±1.27			
X.XXX: ±0.008	X.XX: ±0.203			
MATERIAL	APPROVED (A)			
Pre galvanized (G60)	APPROVED (Customer)			
FINISH	CADDY	ORBIT	RACO	
NO OIL	-	-	-	
SIZE	DWG NO.		REV	
A4	ZQJHxxACMxx			
SCALE: 1:1	PRINT DATE	REFERENCES	SHEET 1 OF 1	

Catalog Number	B	C	D	Diameter(ΦA)	Cable capacity Cat 6/Cat 5e/Fiber Optic	Static Load(F)	Standard Box Quantity
ZQJH12ACPBC	78.8 [3.10]	22.0 [0.87]	14.9 [0.59]	3/4"	10/16/16	60LBS	50
ZQJH21ACPBC	107.3 [4.22]	34.1 [1.34]	14.9 [0.59]	1-5/16"	30/50/50	60LBS	50
ZQJH32ACPBC	118.0 [4.65]	35.0 [1.38]	14.9 [0.59]	2"	50/80/80	60LBS	50
ZQJH64ACPBC	178.0 [7.01]	49.0 [1.93]	14.9 [0.59]	4"	185/300/300	60LBS	25
ZQJH96ACPBC	178.0 [7.01]	49.0 [1.93]	14.9 [0.59]	6"	230/450/450	60LBS	25

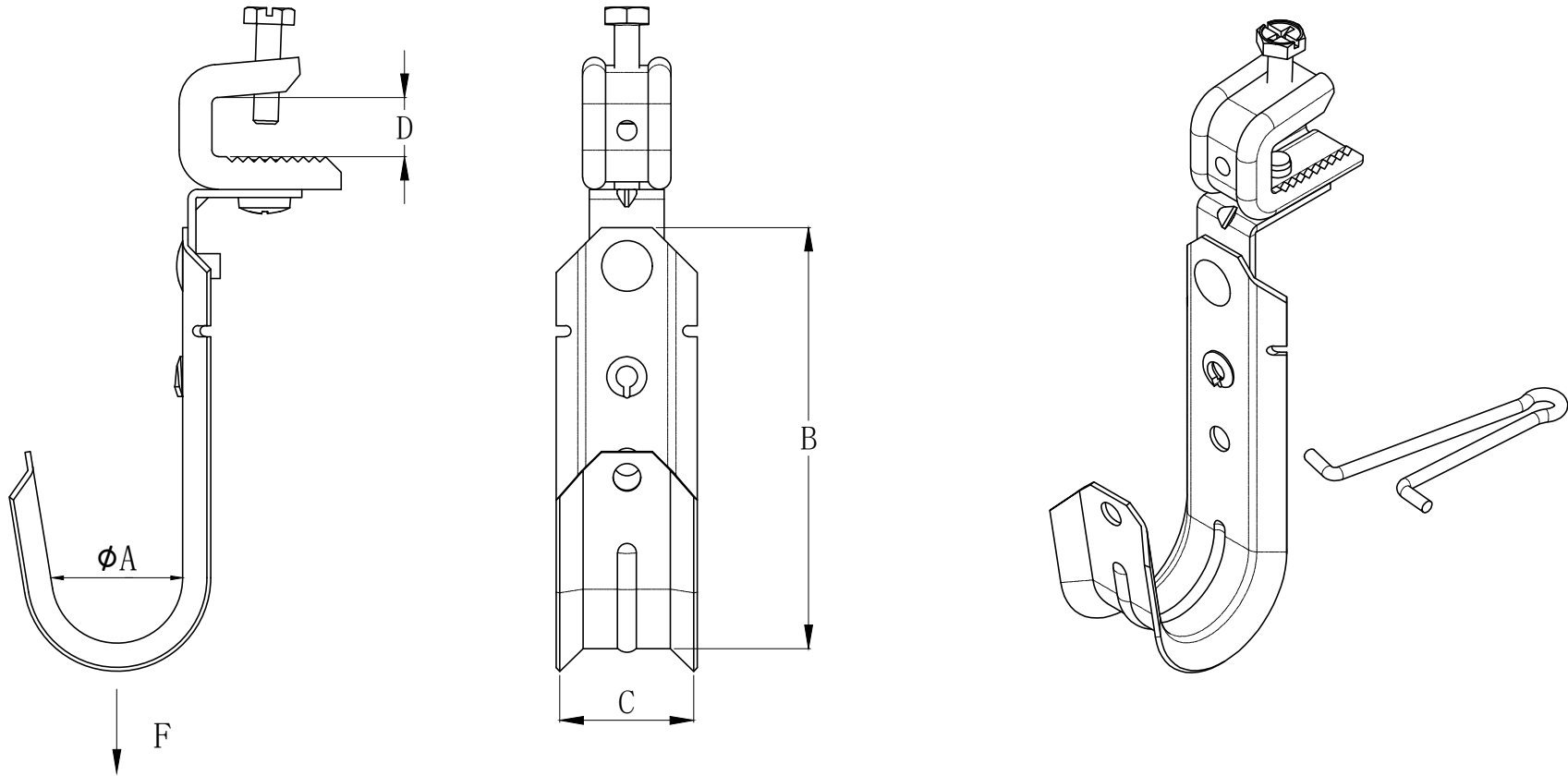

NOTES:

- Material: J HOOK: Pre galvanized steel (G60) , Thickness: 1.35mm [0.053] ;
Angle Bracket: Pre galvanized steel (G60) , Thickness: 2.0mm [0.079];
Beam Clamp: C.R.S, Thickness:2.0mm[0.079],Finish:Zinc plated ;
- Wire retainer available

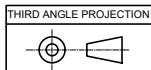

MATERIAL	Pre galvanized (G60)
FINISH	NO OIL

	NAME	DATE
DRAMN	YUAN	2022. 8. 17
CHECKED		
APPROVED (A)		
APPROVED (Customer)		

		Hangzhou Zhiqi Electrical co.,Ltd Tel:86-571-82807601 Email: Linda@zhiqi-china.com	
		TITLE	
J HOOK WITH 360 DEG PRESSED BEAM CLAMP			
SIZE	DWG NO.	REV	
A4	ZQJHxxACPBC		
SCALE: 1:1	PRINT DATE	REFERENCES	SHEET 1 OF 1

Catalog Number	B	C	D	Diameter(Φ A)	Cable capacity Cat 6/Cat 5e/Fiber Optic	Static Load(F)	Standard Box Quantity
ZQJH12ACSSBC	78.8[3.10]	22.0 [0.87]	18.3 [0.72]	3/4"	10/16/16	60LBS	50
ZQJH21ACSSBC	107.3 [4.22]	34.1 [1.34]	18.3 [0.72]	1-5/16"	30/50/50	60LBS	50
ZQJH32ACSSBC	118.0 [4.65]	35.0 [1.38]	18.3 [0.72]	2"	50/80/80	60LBS	50
ZQJH64ACSSBC	178.0 [7.01]	49.0 [1.93]	18.3 [0.72]	4"	185/300/300	60LBS	25
ZQJH96ACSSBC	178.0 [7.01]	49.0 [1.93]	18.3 [0.72]	6"	230/450/450	60LBS	25

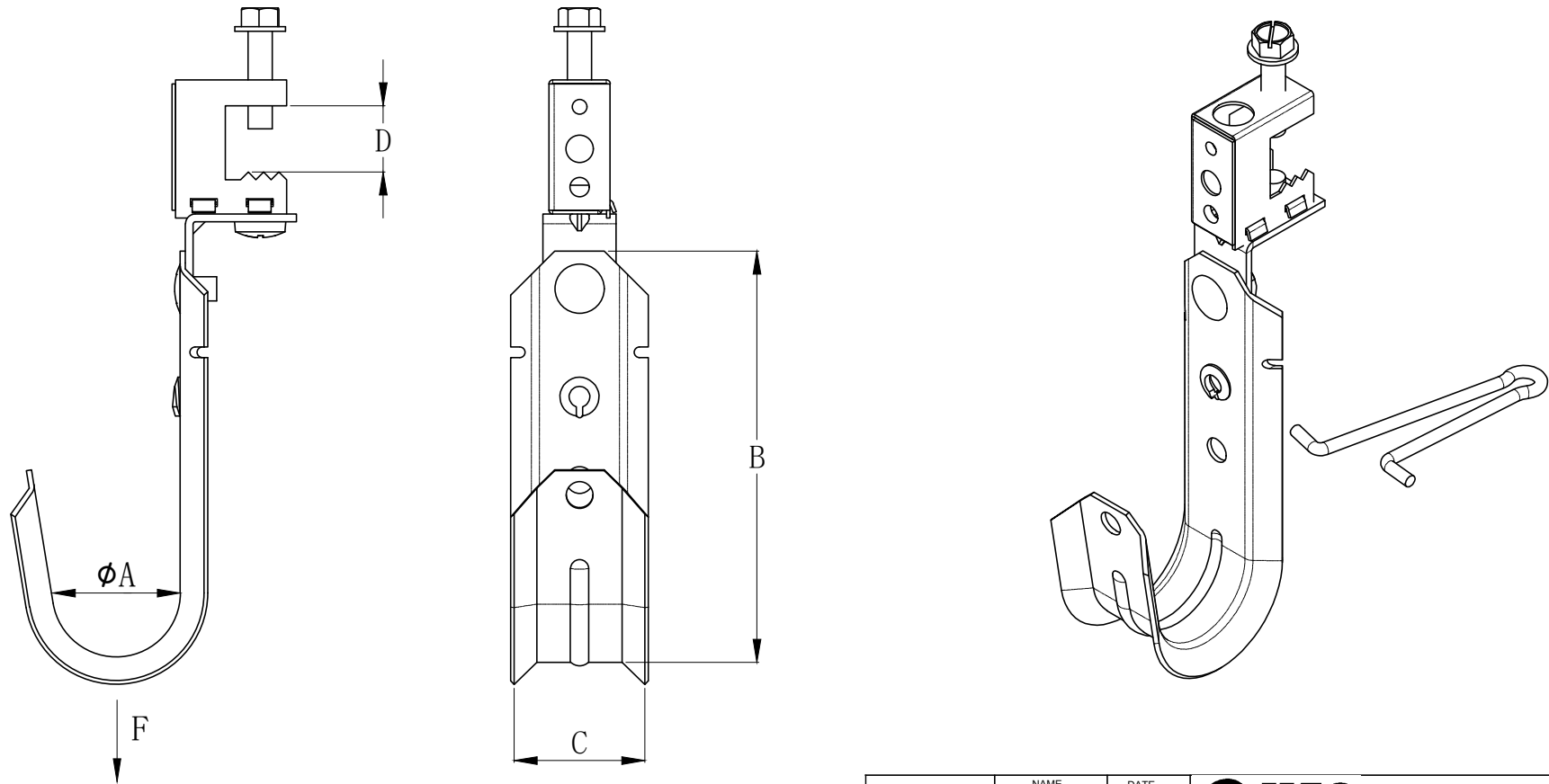

NOTES:

- Material: J HOOK: Pre galvanized steel (G60) , Thickness: 1.35mm [0.053] ;
 Angle Bracket: Pre galvanized steel (G60) , Thickness: 2.0mm [0.079];
 Beam Clamp: C1065 steel, Thickness: 0.8mm [0.031]. Finisi:Black E-coating.
- Wire retainer available.

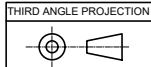

NAME	DATE	 Hangzhou Zhiqi Electrical co.,Ltd <small>Tel:86-571-82807601 Email: Linda@zhiqi-china.com</small>	
DRAMN	YUAN	2022. 8. 17	
CHECKED			
APPROVED (A)			
APPROVED (Customer)			
MATERIAL		Pre galvanized (G60)	
FINISH		NO OIL	
SIZE	DWG NO.	REV	
A4	ZQJHxxACSSBC		
SCALE: 1:1	PRINT DATE	REFERENCES	SHEET 1 OF 1

Catalog Number	B	C	Diameter(Φ A)	Flange Thickness (FT)	Cable capacity Cat 6/Cat 5e/Fiber Optic	Static Load(F)	Standard Box Quantity
ZQJH12HOK-24	78.8[3.10]	22.0 [0.87]	3/4"	1/8"-1/4"	10/16/16	60LBS	50
ZQJH12HOK-58	78.8[3.10]	22.0 [0.87]	3/4"	5/16"-1/2"	10/16/16	60LBS	50
ZQJH12HOK-912	78.8[3.10]	22.0 [0.87]	3/4"	9/16"-3/4"	10/16/16	60LBS	50
ZQJH21HOK-24	107.3 [4.22]	34.1 [1.34]	1-5/16"	1/8"-1/4"	30/50/50	60LBS	50
ZQJH21HOK-58	107.3 [4.22]	34.1 [1.34]	1-5/16"	5/16"-1/2"	30/50/50	60LBS	50
ZQJH21HOK-912	107.3 [4.22]	34.1 [1.34]	1-5/16"	9/16"-3/4"	30/50/50	60LBS	50
ZQJH32HOK-24	118.0 [4.65]	35.0 [1.38]	2"	1/8"-1/4"	50/80/80	60LBS	50
ZQJH32HOK-58	118.0 [4.65]	35.0 [1.38]	2"	5/16"-1/2"	50/80/80	60LBS	50
ZQJH32HOK-912	118.0 [4.65]	35.0 [1.38]	2"	9/16"-3/4"	50/80/80	60LBS	50
ZQJH64HOK-24	178.0 [7.01]	49.0 [1.93]	4"	1/8"-1/4"	185/300/300	60LBS	25
ZQJH64HOK-58	178.0 [7.01]	49.0 [1.93]	4"	5/16"-1/2"	185/300/300	60LBS	25
ZQJH64HOK-912	178.0 [7.01]	49.0 [1.93]	4"	9/16"-3/4"	185/300/300	60LBS	25
ZQJH96HOK-24	178.0 [7.01]	49.0 [1.93]	6"	1/8"-1/4"	230/450/450	60LBS	25
ZQJH96HOK-58	178.0 [7.01]	49.0 [1.93]	6"	5/16"-1/2"	230/450/450	60LBS	25
ZQJH96HOK-912	178.0 [7.01]	49.0 [1.93]	6"	9/16"-3/4"	230/450/450	60LBS	25

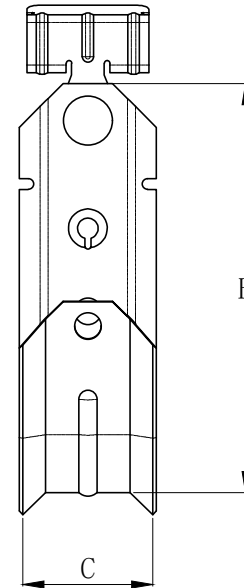
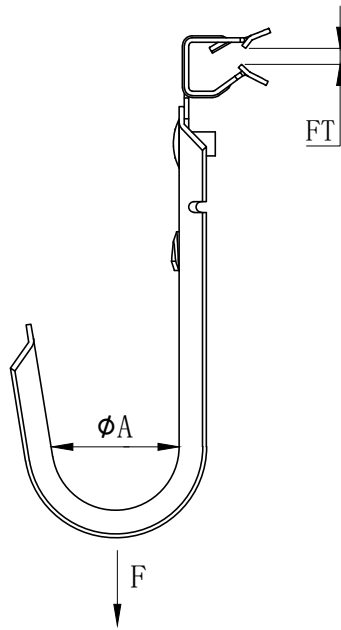
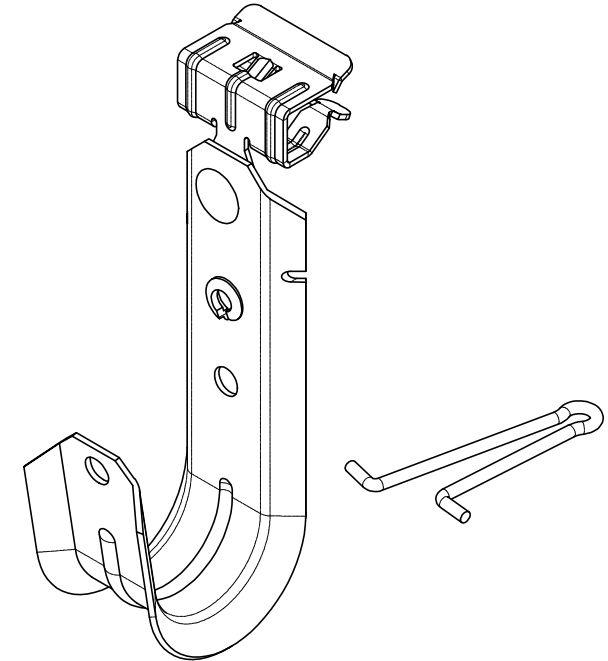

NOTES:

- 1.Material: J HOOK: Pre galvanized steel (G60) , Thickness: 1.35mm [0.053] .
Beam Clamp: C1065 steel , Thickness: 1.2mm [0.047].Finish: Black E-coating
- 2.Wire retainer available

TOLERANCES UNLESS OTHERWISE SPECIFIED		NAME	DATE	Hangzhou Zhiqi Electrical co.,Ltd Tel:86-571-82807601 Email: Linda@zhiqi-china.com
INCHES	MILLIMETER	YUAN	2022. 8. 17	
ANGULAR: X X: ±0.1 X.X X: ±0.05 X.X X X: ±0.008	ANGULAR: X: ±2.54 X.X: ±1.27 X.X X: ±0.203			
MATERIAL Pre galvanized (G60)	APPROVED (A)			
FINISH NO OIL	APPROVED (Customer)			
	CADDY	ORBIT	RACO	
	-	-	-	
SIZE A4	DWG NO. ZQJHxxHOK-xx	REV		
SCALE: 1:1	PRINT DATE	REFERENCES	SHEET 1 OF 1	

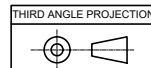

Catalog Number	B	C	D	Diameter(Φ A)	Cable capacity Cat 6/Cat 5e/Fiber Optic	Static Load(F)	Standard Box Quantity
ZQJH12PBC	78.8 [3.10]	22.0 [0.87]	14.9 [0.59]	3/4"	10/16/16	60LBS	50
ZQJH21PBC	107.3 [4.22]	34.1 [1.34]	14.9 [0.59]	1-5/16"	30/50/50	60LBS	50
ZQJH32PBC	118.0 [4.65]	35.0 [1.38]	14.9 [0.59]	2"	50/80/80	60LBS	50
ZQJH64PBC	178.0 [7.01]	49.0 [1.93]	14.9 [0.59]	4"	185/300/300	60LBS	25
ZQJH96PBC	178.0 [7.01]	49.0 [1.93]	14.9 [0.59]	6"	230/450/450	60LBS	25

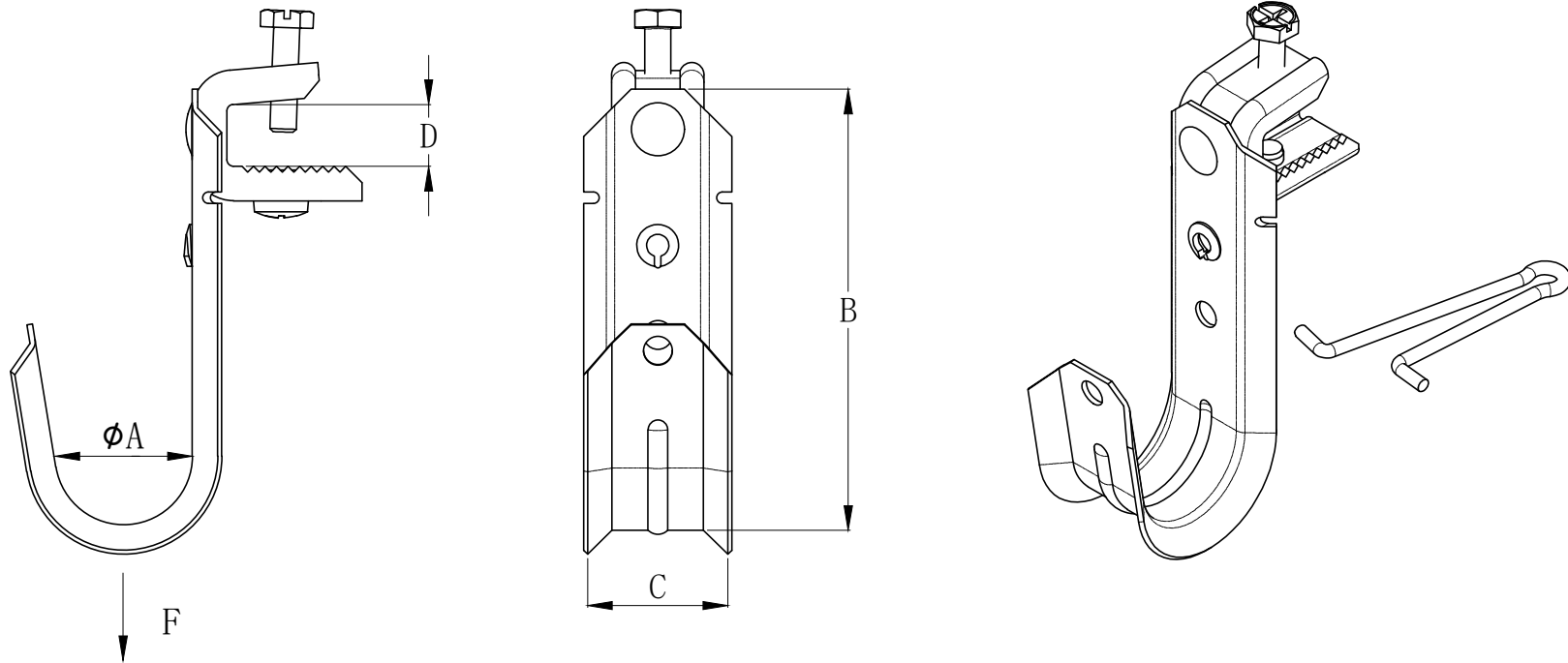

NOTES:

1. Material: J HOOK: Pre galvanized steel (G60) , Thickness: 1.35mm [0.053] ;
Beam Clamp: C.R.S, Thickness:2.0mm[0.079], Finish:Zinc plated ;
2. Wire retainer available;

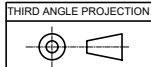

MATERIAL	Pre galvanized (G60)
FINISH	NO OIL

	NAME	DATE
DRAMN	YUAN	2022. 8. 17
CHECKED		
APPROVED (A)		
APPROVED (Customer)		

		Hangzhou Zhiqi Electrical co.,Ltd <small>Tel:86-571-82807601 Email: Linda@zhiqi-china.com</small>	
		TITLE J HOOK WITH PRESSED BEAM CLAMP	
SIZE	DWG NO.	REV	
A4	ZQJHxxPBC		
SCALE: 1:1	PRINT DATE	REFERENCES	SHEET 1 OF 1

Catalog Number	B	C	D	Diameter(ΦA)	Cable capacity Cat 6/Cat 5e/Fiber Optic	Static Load(F)	Standard Box Quantity
ZQJH12SSBC	78.8[3.10]	22.0 [0.87]	18.3 [0.72]	3/4"	10/16/16	60LBS	50
ZQJH21SSBC	107.3 [4.22]	34.1 [1.34]	18.3 [0.72]	1-5/16"	30/50/50	60LBS	50
ZQJH32SSBC	118.0 [4.65]	35.0 [1.38]	18.3 [0.72]	2"	50/80/80	60LBS	50
ZQJH64SSBC	178.0 [7.01]	49.0 [1.93]	18.3 [0.72]	4"	185/300/300	60LBS	25
ZQJH96SSBC	178.0 [7.01]	49.0 [1.93]	18.3 [0.72]	6"	230/450/450	60LBS	25

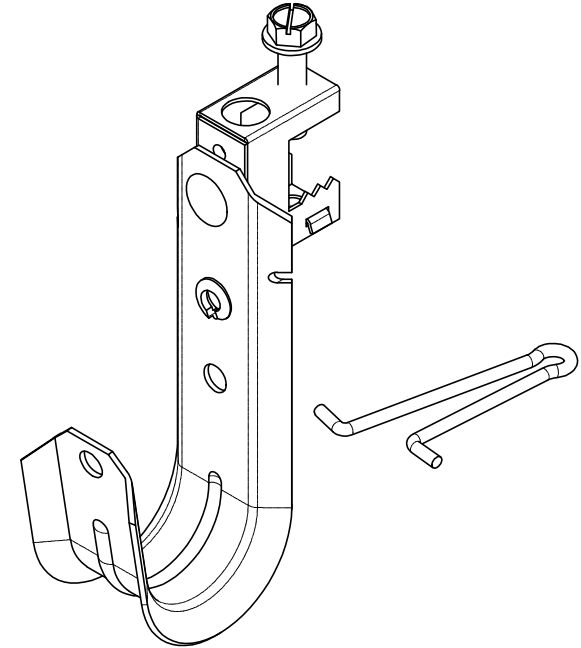
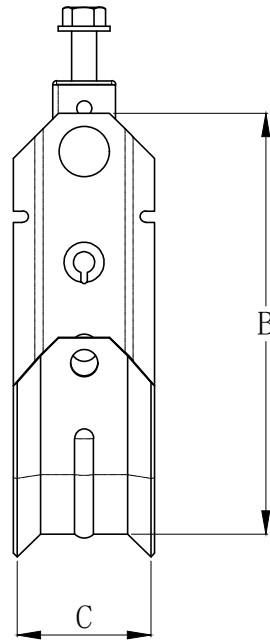
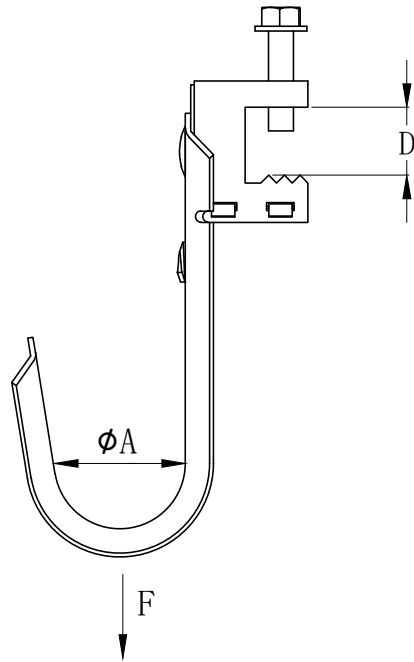

NOTES:

1. Material: J HOOK: Pre galvanized steel (G60) , Thickness: 1.35mm [0.053] .
Beam Clamp: C1065 steel, Thickness: 0.8mm [0.031]. Finish: Black E-coating
2. Wire retainer available

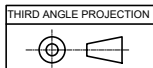

MATERIAL
Pre galvanized (G60)
FINISH
NO OIL

	NAME	DATE
DRAMN	YUAN	2022. 8. 17
CHECKED		
APPROVED (A)		
APPROVED (Customer)		

HZO Hangzhou Zhiqi Electrical co.,Ltd
ELECTRIC Tel:86-571-82807601 Email: Linda@zhiqi-china.com

TITLE
J HOOK WITH STAMPED STEEL BEAM CLAMP

SIZE	DWG NO.	REV
A4	ZQJHxxSSBC	
SCALE: 1:1	PRINT DATE	REFERENCES
		SHEET 1 OF 1

Catalog Number	B	C	Rod Size(RS)	Diameter(Φ A)	Cable capacity Cat 6/Cat 5e/Fiber Optic	Static Load(F)	Standard Box Quantity
ZQJH12W	78.8[3.10]	22.0 [0.87]	1/4"	3/4"	10/16/16	60LBS	50
ZQJH21W	107.3 [4.22]	34.1 [1.34]	1/4"	1-5/16"	30/50/50	60LBS	50
ZQJH32W	118.0 [4.65]	35.0 [1.38]	1/4"	2"	50/80/80	60LBS	50
ZQJH64W	178.0 [7.01]	49.0 [1.93]	1/4"	4"	185/300/300	60LBS	25
ZQJH96W	178.0 [7.01]	49.0 [1.93]	1/4"	6"	230/450/450	60LBS	25

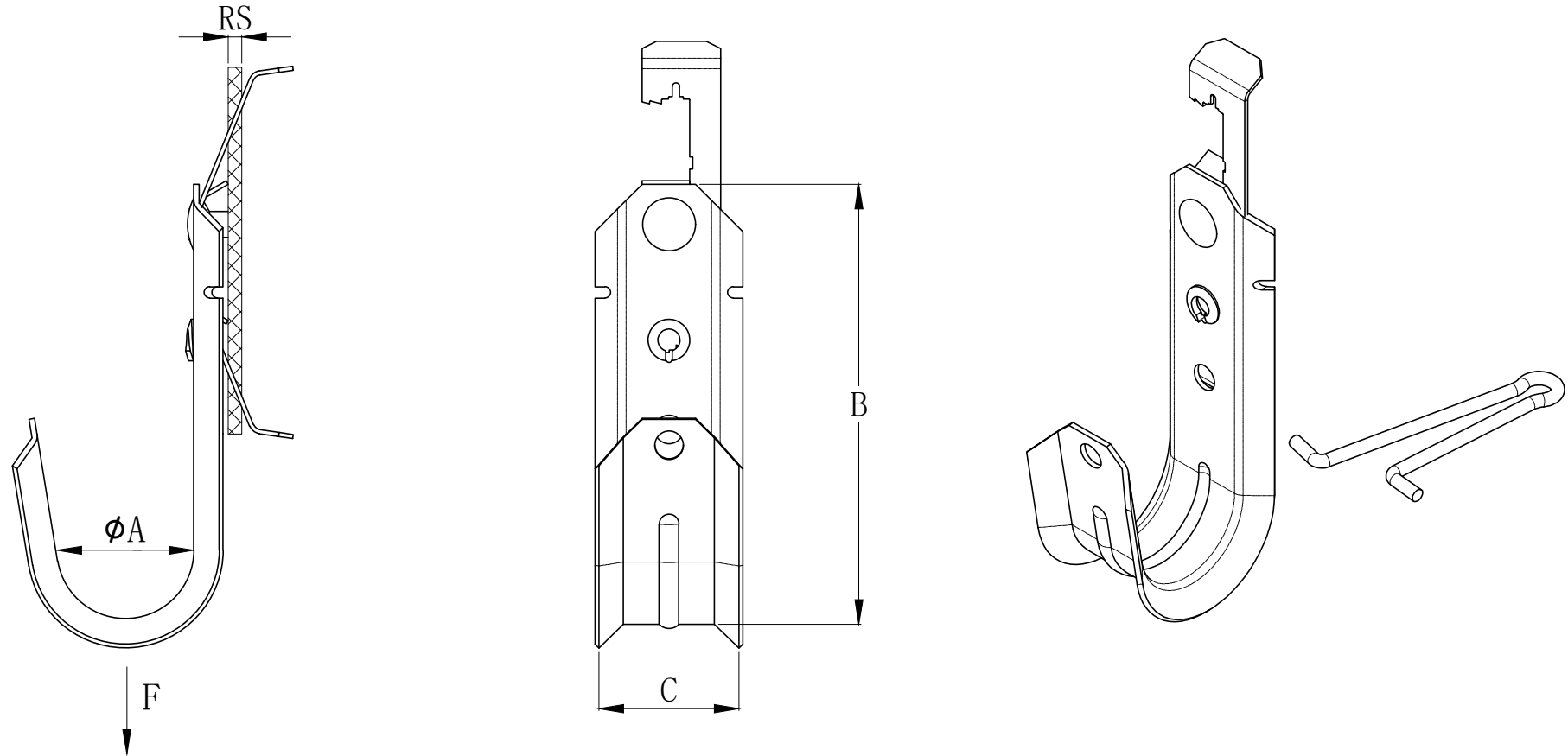

NOTES:
 1.Material: J HOOK: Pre galvanized steel (G60) , Thickness: 1.35mm [0.053] .
 Bat Wing: C1065 steel .Thickness:1.00mm[0.039],Finish: Black E-coating;
 2.Wire retainer available

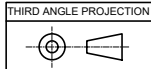

MATERIAL	Pre galvanized (G60)
FINISH	NO OIL

	NAME	DATE
DRAMN	YUAN	2022. 8. 17
CHECKED		
APPROVED (A)		
APPROVED (Customer)		

HZO Hangzhou Zhiqi Electrical co.,Ltd
 ELECTRIC Tel:86-571-82807601 Email: Linda@zhiqi-china.com

TITLE		
J HOOK WITH BATWING		
SIZE	DWG NO.	REV
A4	ZQJHxxW	
SCALE: 1:1	PRINT DATE	REFERENCES
		SHEET 1 OF 1