

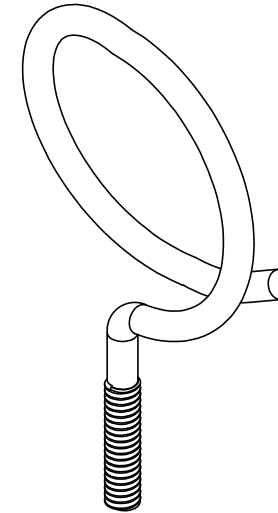

Catalog Number	SIZE(ΦA)	THREAD(B)	C	D	LOADING CAPACITY	STD PKG.
ZQBR125	1-1/4"	1/4-20	25.4 [1.00]	11.0 [0.43]	50	100
ZQBR150	1-1/2"	1/4-20	25.4 [1.00]	11.0 [0.43]	50	100
ZQBR200	2"	1/4-20	25.4 [1.00]	11.0 [0.43]	50	100
ZQBR400	4"	1/4-20	25.4 [1.00]	25.4 [1.00]	50	100
ZQBR501024	1/4"	10-24	15.0 [0.59]	6.5 [0.26]	50	100
ZQBR751024	3/4"	10-24	15.0 [0.59]	6.3 [0.25]	50	100
ZQBR1001024	1"	10-24	15.0 [0.59]	11.0 [0.43]	50	100
ZQBR1251024	1-1/4"	10-24	15.0 [0.59]	11.0 [0.43]	50	100
ZQBR1501024	1-1/2"	10-24	27.0 [1.06]	11.0 [0.43]	50	100
ZQBR2001024	2"	10-24	15.0 [0.59]	11.0 [0.43]	50	100

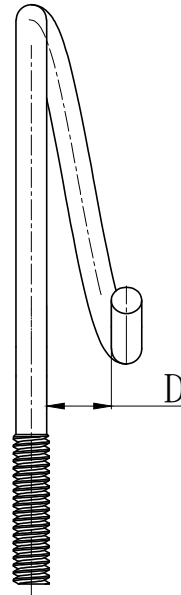
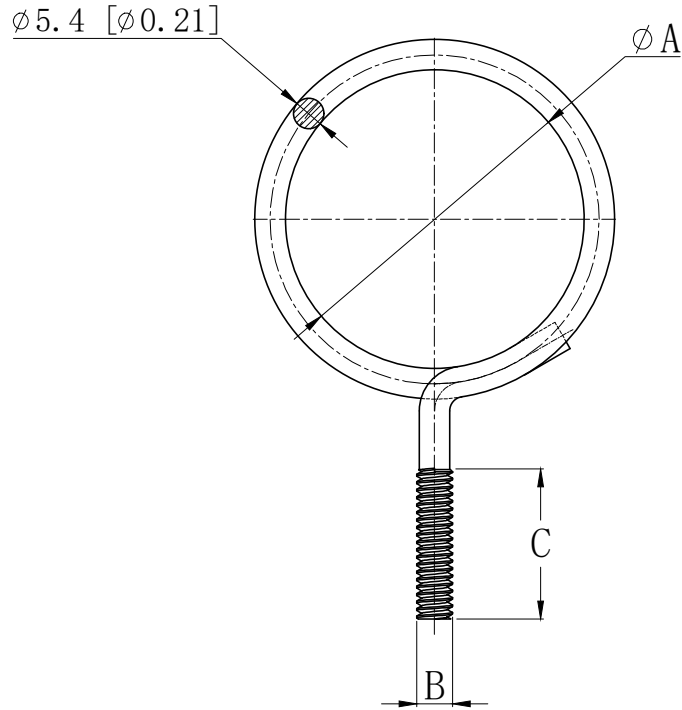

NOTES:

- 1.All dimensions in millimeters and [inches];
- 2.Material:Steel C1008~C1018 ,
Finish:Zinc plated ,thickness:0.005mm[0.0002in];
- 3.Free of sharp edge and burrs.max burr 0.127[0.005];

TOLERANCES UNLESS OTHERWISE SPECIFIED		NAME	DATE	 Hangzhou Zhiqi Electrical co.,Ltd Tel:86-571-82807601 Email: Linda@zhiqi-china.com	
INCHES:	MILLIMETER:	DRAMN	YUAN		2022. 8. 25
ANGULAR:	ANGULAR:	CHECKED			
X.X: ±0.1	X: ±2.54	APPROVED (A)			
X.XX: ±0.05	X.X: ±1.27	APPROVED (Customer)			
X.XXX: ±0.008	X.XX: ±0.203				
MATERIAL		Steel C1008-C1018			TITLE
FINISH		NO OIL			Bridle Ring Data Sheet
THIRD ANGLE PROJECTION		CADDY	ORBIT	RACO	SIZE
		-	-	-	A4
					DWG NO.
					ZQBRxx
					REV
					A
		SCALE: 1:1	PRINT DATE	REFERENCES	SHEET 1 OF 1

Catalog Number	SIZE(ΦA)	Pull Strength(F)	B	LOADING CAPACITY	STD PKG.
ZQBR150MAG	1-1/2"	90LBS	11.0 [0.43]	50	100
ZQBR200MAG	2"	90LBS	11.0 [0.43]	50	100
ZQBR400MAG	4"	90LBS	25.4 [1.00]	50	100

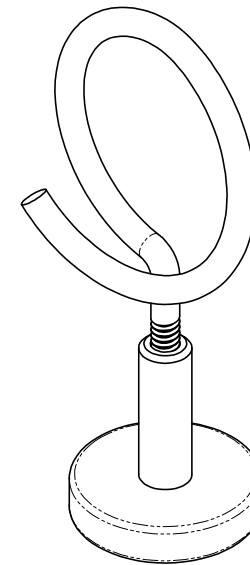
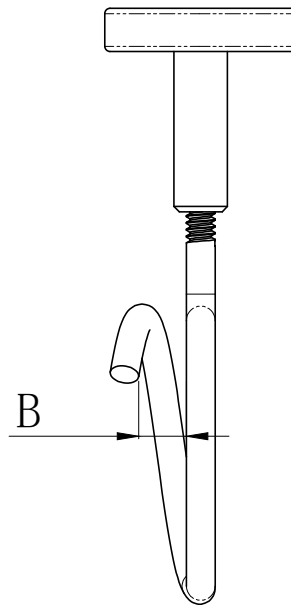
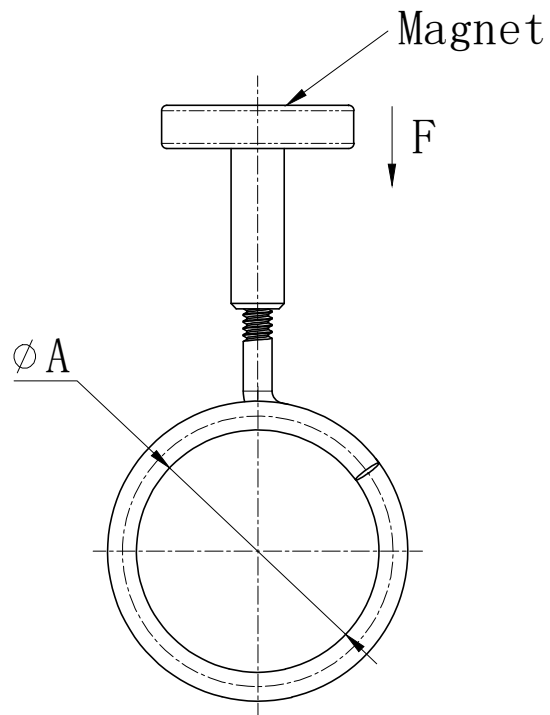

NOTES:

1.All dimensions in millimeters and [inches];

2.Material:

Bridle Ring:Steel C1008~C1018 ,
Finish:Zinc plated ,thickness:0.005mm[0.0002in];

Heavy Load Magnetic:N45 Magnet

3.Free of sharp edge and burrs.max burr 0.127[0.005];

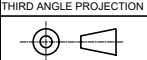
TOLERANCES UNLESS OTHERWISE SPECIFIED		NAME	DATE	 Hangzhou Zhiqi Electrical co.,Ltd Tel:86-571-82807601 Email: Linda@zhiqi-china.com
INCHES	MILLIMETER	YUAN	2022. 10. 21	
ANGULAR:	ANGULAR:			
X.X: ±0.1	X: ±2.54			
X.XX: ±0.05	X.X: ±1.27			
X.XXX: ±0.008	X.XX: ±0.203			
MATERIAL	APPROVED (A)			
Steel C1008~C1018	APPROVED (Customer)			
FINISH	CADDY	ORBIT	RACO	
NO OIL	-	-	-	
THIRD ANGLE PROJECTION	SIZE		DWG NO.	REV
	A4		ZQBRxxMAG	A
	SCALE: 1:1	PRINT DATE	REFERENCES	SHEET 1 OF 1

TITLE
Bridle Rings With Heavy Load Magnetic Data Sheet

Catalog Number	SIZE(ΦA)	B	C	D	LOADING CAPACITY	STD PKG.
ZQBR150NP	1-1/2"	36.3 [1.43]	51.0 [2.01]	11.0 [0.43]	50	100
ZQBR200NP	2"	36.3 [1.43]	51.0 [2.01]	11.0 [0.43]	50	100
ZQBR400NP	4"	36.3 [1.43]	51.0 [2.01]	25.4 [1.00]	50	100

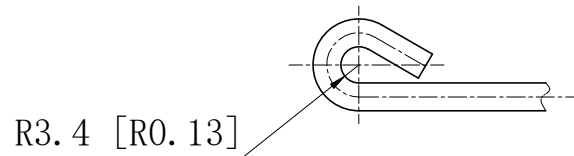
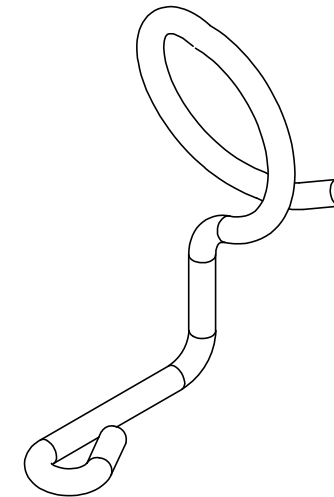
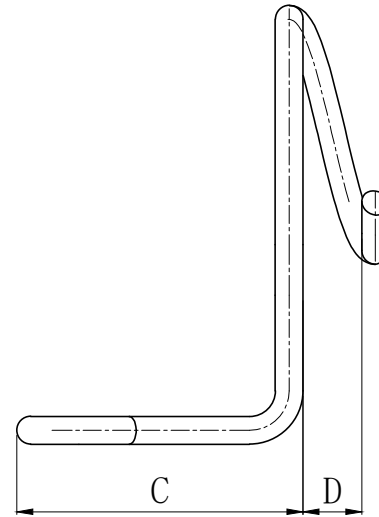
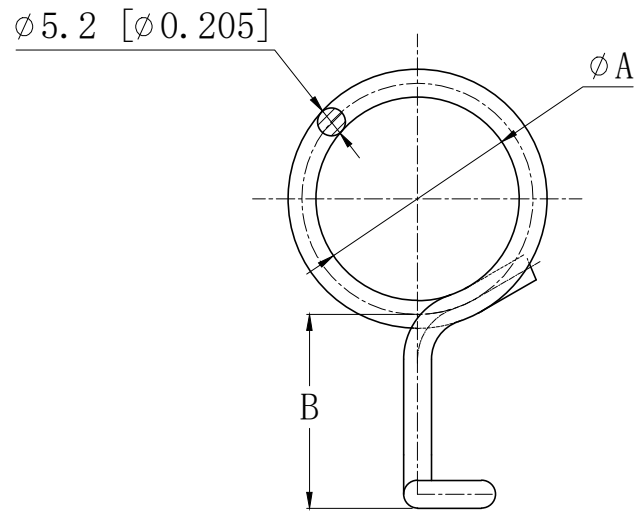

NOTES:

- 1.All dimensions in millimeters and [inches];
- 2.Material:Steel C1008~C1018 ,
Finish:Zinc plated ,thickness:0.005mm[0.0002in];
- 3.Free of sharp edge and burrs.max burr 0.127[0.005];

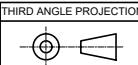
TOLERANCES UNLESS OTHERWISE SPECIFIED		NAME	DATE	 Hangzhou Zhiqi Electrical co.,Ltd Tel:86-571-82807601 Email: Linda@zhiqi-china.com	
INCHES:	MILLIMETER:	YUAN	2022. 10. 21		
ANGULAR:	ANGULAR:				
X.X: ±0.1	X: ±2.54				
X.XX: ±0.05	X.X: ±1.27				
X.XXX: ±0.008	X.XX: ±0.203				
MATERIAL	APPROVED (A)				
Steel C1008~C1018	APPROVED (Customer)				
FINISH	CADDY	ORBIT	RACO		
NO OIL	-	-	-		
THIRD ANGLE PROJECTION			SIZE	DWG NO.	REV
			A4	ZQBRxxNP	A
	SCALE: 1:1	PRINT DATE	REFERENCES	SHEET 1 OF 1	

TITLE
Screw-Mount Bridle Ring Data Sheet

Catalog Number	SIZE(Φ A)	B	C	LOADING CAPACITY	STD PKG.
ZQ150NPSAD	1-1/2"	37.2 [1.46]	51.0 [2.01]	50	100
ZQ200NPSAD	2"	37.2 [1.46]	51.0 [2.01]	50	100

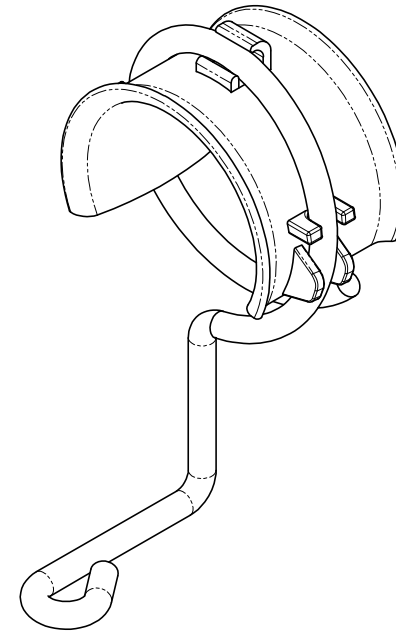
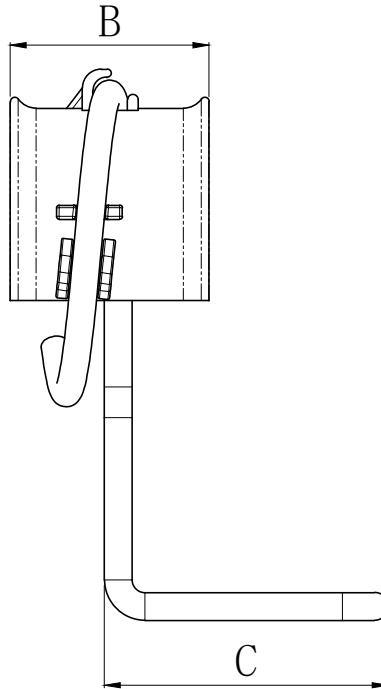
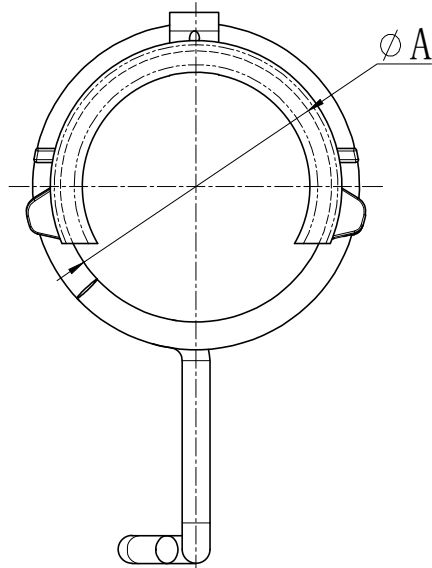

NOTES:

1.All dimensions in millimeters and [inches];

2.Material:

Bridge Ring: Steel C1008~C1018 ,

Finish:Zinc plated ,thickness:0.005mm[0.0002in];

Data Cable Saddle: PE

3.Free of sharp edge and burrs.max burr 0.127[0.005];

TOLERANCES UNLESS OTHERWISE SPECIFIED		NAME	DATE	 Hangzhou Zhiqi Electrical co.,Ltd Tel:86-571-82807601 Email: Linda@zhiqi-china.com
INCHES:	MILLIMETER	YUAN	2022. 10. 21	
ANGULAR:	ANGULAR:			
X.X: ±0.1	X: ±2.54			
X.XX: ±0.05	X.X: ±1.27			
X.XXX: ±0.008	X.XX: ±0.203			
MATERIAL		APPROVED (A)		
Steel C1008~C1018		APPROVED (Customer)		
FINISH	CADDY	ORBIT	RACO	
NO OIL	-	-	-	
THIRD ANGLE PROJECTION				
SIZE	DWG NO.	REV		
A4	ZQBRxxNPSAD	A		
SCALE: 1:1	PRINT DATE	REFERENCES	SHEET 1 OF 1	

TITLE
Screw-Mount Bridge Ring
With Data Cable Saddle Data Sheet

Catalog Number	SIZE(ΦA)	THREADLEG(B)	C	LOADING CAPACITY	STD PKG.
ZQBR150SAD	1-1/2"	1/4-20	25.4 [1.00]	50	100
ZQBR200SAD	2"	1/4-20	25.4 [1.00]	50	100
ZQBR400SAD	4"	1/4-20	25.4 [1.00]	50	100

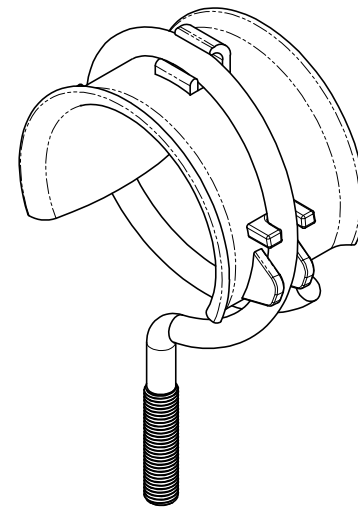
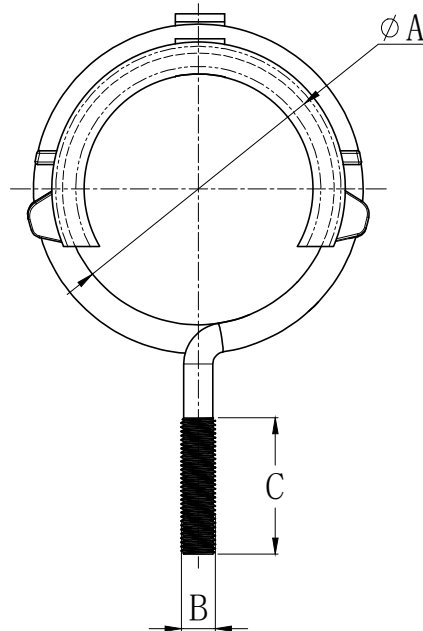
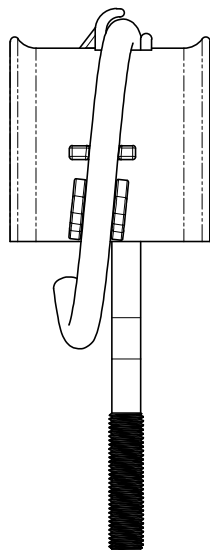

NOTES:

1.All dimensions in millimeters and [inches];

2.Material:

Bridle Ring: Steel C1008~C1018 ,

Finish:Zinc plated ,thickness:0.005mm[0.0002in];

Data Cable Saddle: PE

3.Free of sharp edge and burrs.max burr 0.127[0.005];

TOLERANCES UNLESS OTHERWISE SPECIFIED		NAME	DATE	 Hangzhou Zhiqi Electrical co.,Ltd Tel:86-571-82807601 Email: Linda@zhiqi-china.com
INCHES:	MILLIMETER	YUAN	2022. 10. 21	
ANGULAR:	ANGULAR:			
X X: ±0.1	X: ±2.54			
X X X: ±0.05	X X: ±1.27			
X X X X: ±0.008	X X X: ±0.203			
MATERIAL	APPROVED (A)			TITLE
Steel C1008~C1018	APPROVED (Customer)			Bridle Ring With Data Cable Saddle Data Sheet
FINISH	CADDY	ORBIT	RACO	SIZE
NO OIL	-	-	-	A4
				DWG NO.
				ZQBRxxSAD
				REV
				A
				SCALE: 1:1
				PRINT DATE
				REFERENCES
				SHEET 1 OF 1

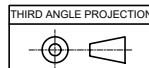

Catalog Number	SIZE(ΦA)	B	C	D	LOADING CAPACITY	STD PKG.
ZQ150SADWS	1-1/2"	37.2 [1.46]	25.4 [1.00]	#16×1" WOOD SCREW	50	100
ZQ200SADWS	2"	37.2 [1.46]	25.4 [1.00]	#16×1" WOOD SCREW	50	100

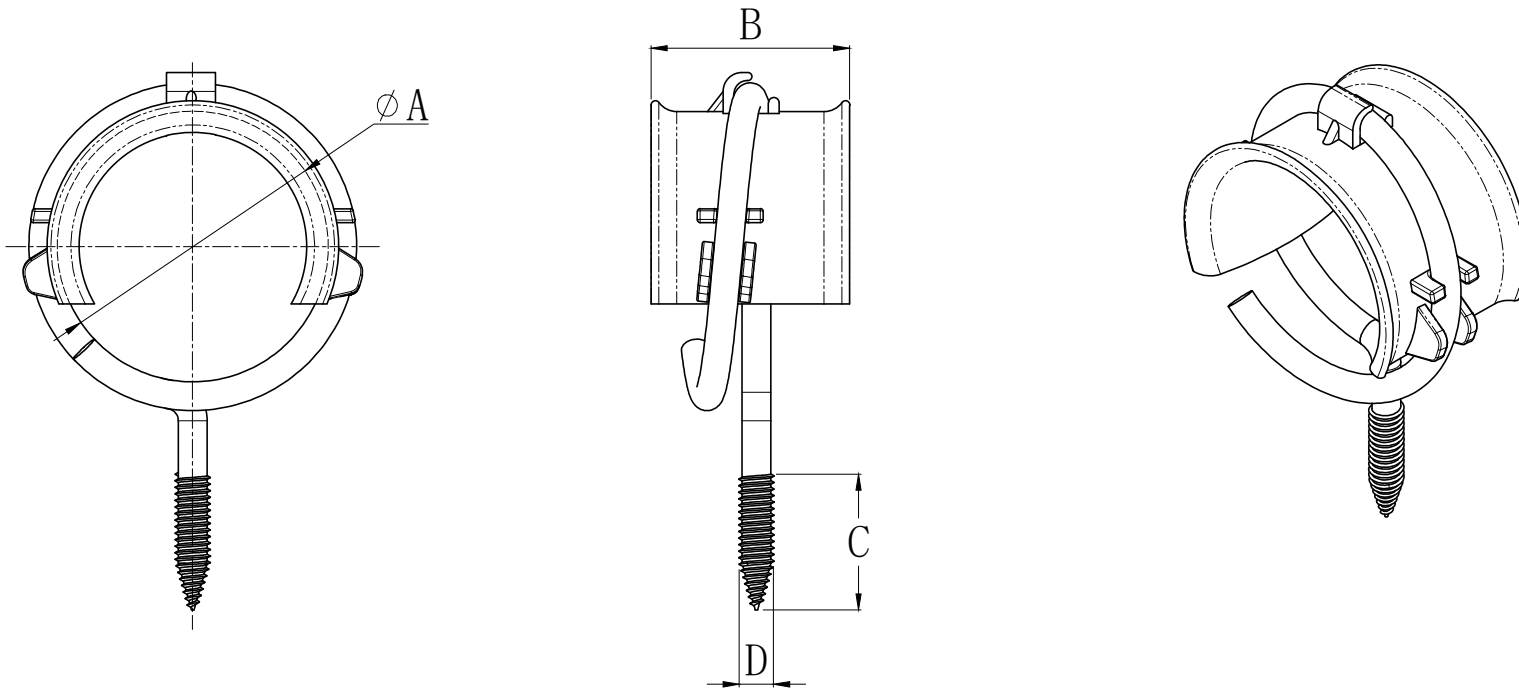

NOTES:

1.All dimensions in millimeters and [inches];

2.Material:

Bridle Ring: Steel C1008~C1018 ,

Finish:Zinc plated ,thickness:0.005mm[0.0002in];

Data Cable Saddle: PE

3.Free of sharp edge and burrs.max burr 0.127[0.005];

TOLERANCES UNLESS OTHERWISE SPECIFIED		NAME	DATE	 Hangzhou Zhiqi Electrical co.,Ltd Tel:86-571-82807601 Email: Linda@zhiqi-china.com
INCHES:	MILLIMETER	YUAN	2022. 10. 21	
ANGULAR:	ANGULAR:			
X.X: ±0.1	X: ±2.54			
X.XX: ±0.05	X.X: ±1.27			
X.XXX: ±0.008	X.XX: ±0.203			
MATERIAL	APPROVED (A)			
Steel C1008~C1018	APPROVED (Customer)			
FINISH	CADDY	ORBIT	RACO	
NO OIL	-	-	-	
SIZE	DWG NO.	REV		
A4	ZQBRxxSADWS	A		
SCALE: 1:1	PRINT DATE	REFERENCES	SHEET 1 OF 1	

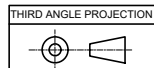

Catalog Number	SIZE (ΦA)	THREAD(B)	C	D	LOADING CAPACITY	STD PKG.
ZQBR125SS	1-1/4"	1/4-20	25.4 [1.00]	11.0 [0.43]	50	100
ZQBR150SS	1-1/2"	1/4-20	25.4 [1.00]	11.0 [0.43]	50	100
ZQBR200SS	2"	1/4-20	25.4 [1.00]	11.0 [0.43]	50	100
ZQBR400SS	4"	1/4-20	25.4 [1.00]	25.4 [1.00]	50	100

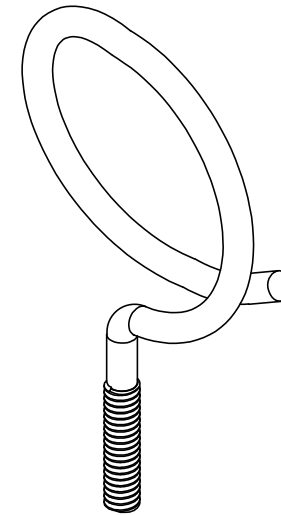
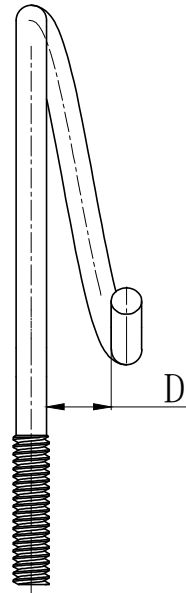
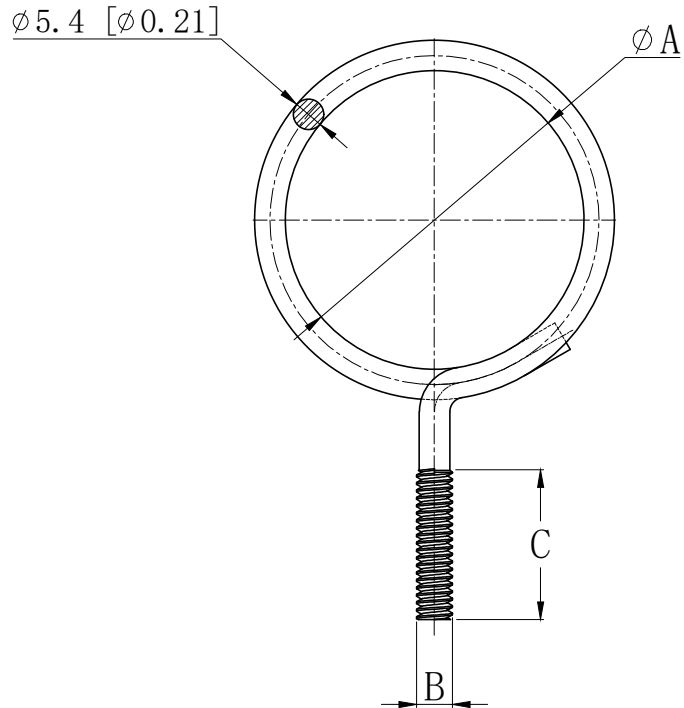

NOTES:

- 1.All dimensions in millimeters and [inches];
- 2.Material:316SS ,
- 3.Free of sharp edge and burrs.max burr 0.127[0.005];

TOLERANCES UNLESS OTHERWISE SPECIFIED		NAME	DATE	 Hangzhou Zhiqi Electrical co.,Ltd Tel:86-571-82807601 Email: Linda@zhiqi-china.com
INCHES:	MILLIMETER	YUAN	2022. 8. 25	
ANGULAR:	ANGULAR:			
X.X: ±0.1	X: ±2.54			
X.XX: ±0.05	X.X: ±1.27			
X.XXX: ±0.008	X.XX: ±0.203			
MATERIAL:		APPROVED (A)		TITLE
316SS		APPROVED (Customer)		316 Stainless Steel Bridle Ring Data Sheet
FINISH:	CADDY	ORBIT	RACO	SIZE
NO OIL	-	-	-	A4
				DWG NO.
				ZQBRxxSS
				REV
				A
				SCALE: 1:1
				PRINT DATE
				REFERENCES
				SHEET 1 OF 1

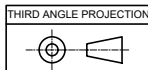

Catalog Number	SIZE(ΦA)	THREAD(B)	C	D	LOADING CAPACITY	STD PKG.
ZQBR100WS	1"	#16×1" WOOD SCREW	25.4 [1.00]	11.0 [0.43]	50	100
ZQBR125WS	1-1/4"	#16×1" WOOD SCREW	25.4 [1.00]	11.0 [0.43]	50	100
ZQBR150WS	1-1/2"	#16×1" WOOD SCREW	25.4 [1.00]	11.0 [0.43]	50	100
ZQBR200WS	2"	#16×1" WOOD SCREW	25.4 [1.00]	11.0 [0.43]	50	100
ZQBR400WS	4"	#16×1" WOOD SCREW	25.4 [1.00]	25.4 [1.00]	50	100

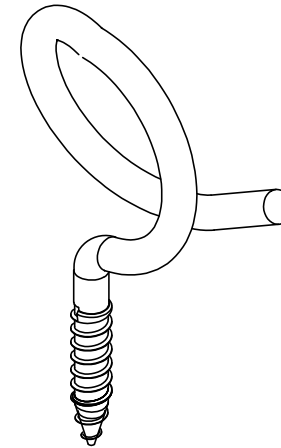
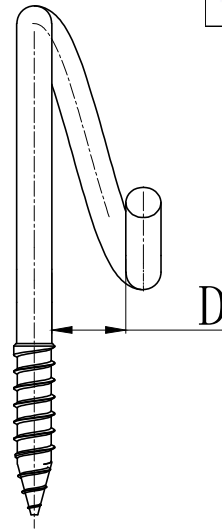
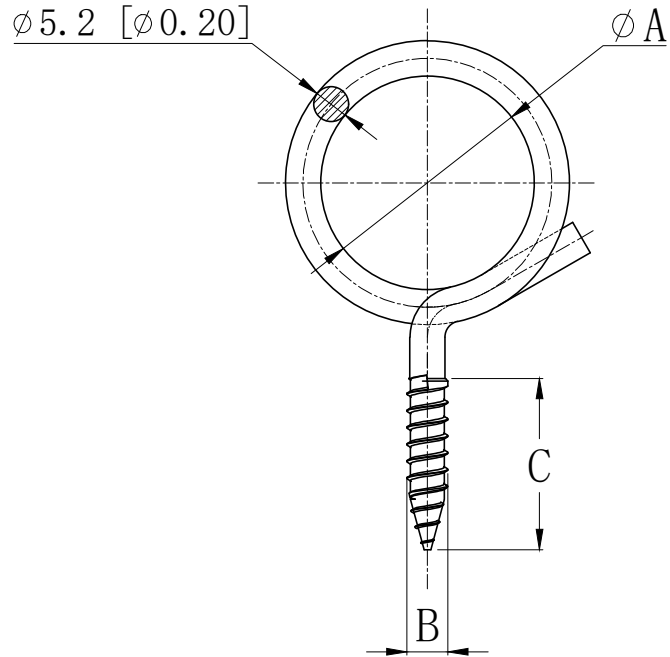

NOTES:

- 1.All dimensions in millimeters and [inches];
- 2.Material:Steel C1008~C1018 ,
Finish:Zinc plated ,thickness:0.005mm[0.0002in];
- 3.Free of sharp edge and burrs.max burr 0.127[0.005];

TOLERANCES UNLESS OTHERWISE SPECIFIED		NAME	DATE	 Hangzhou Zhiqi Electrical co.,Ltd Tel:86-571-82807601 Email: Linda@zhiqi-china.com
INCHES:	MILLIMETER	YUAN	2022. 10. 21	
ANGULAR:	ANGULAR:			
X.X: ±0.1	X: ±2.54			
X.XX: ±0.05	X.X: ±1.27			
X.XXX: ±0.008	X.XX: ±0.203			
MATERIAL:				TITLE
Steel C1008~C1018				Bridge Ring With Wood Screw Data Sheet
FINISH	CADDY	ORBIT	RACO	SIZE
NO OIL	-	-	-	A4
				DWG NO.
				ZQBRxxWS
				REV
				A
				SCALE: 1:1
				PRINT DATE
				REFERENCES
				SHEET 1 OF 1

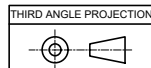

Catalog Number	SIZE(ΦA)	B	Plenum-Rated Saddle	STD PKG.
ZQ150SAD	1-1/2"	37.2[1.46]	Plenum-Rated Saddle	100
ZQ200SAD	2"	37.2[1.46]	Plenum-Rated Saddle	100

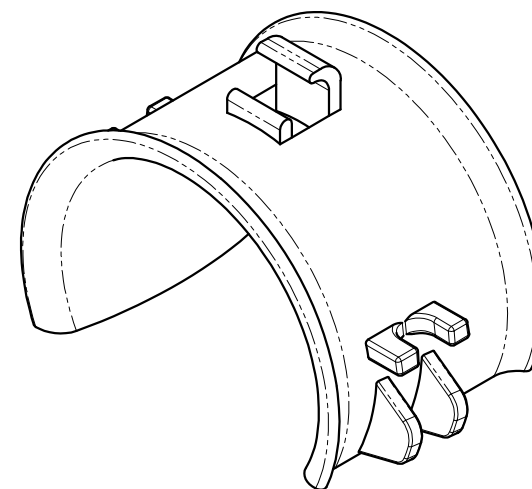
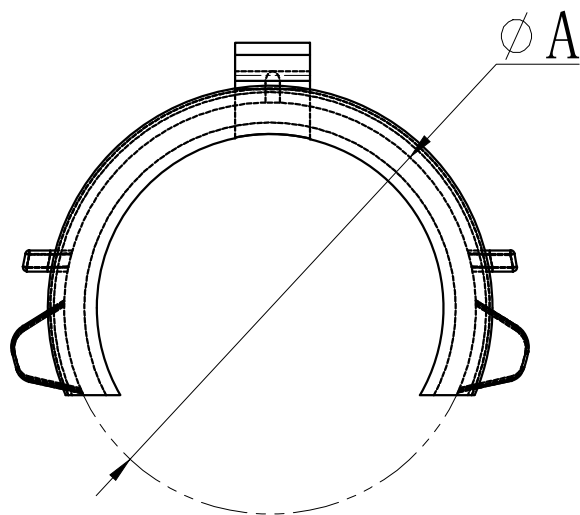
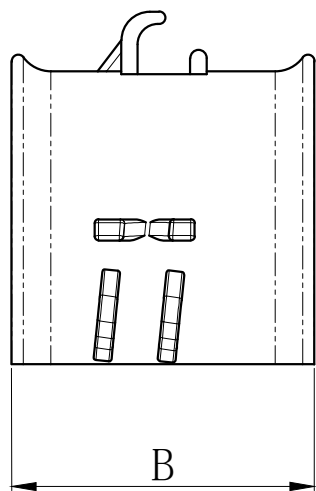

NOTES:

- 1.All dimensions in millimeters and [inches];
- 2.Material:PE ;
- 3.Free of sharp edge and burrs.max burr 0.127[0.005];

TOLERANCES UNLESS OTHERWISE SPECIFIED		NAME	DATE	 Hangzhou Zhiqi Electrical co.,Ltd Tel:86-571-82807601 Email: Linda@zhiqi-china.com
INCHES	MILLIMETER	YUAN	2022. 8. 25	
ANGULAR:	ANGULAR:			
X.X: ±0.1	X: ±2.54			
X.XX: ±0.05	X.X: ±1.27			
X.XXX: ±0.008	X.XX: ±0.203			
MATERIAL		APPROVED (A)		
PE		APPROVED (Customer)		
FINISH		CADDY	ORBIT	RACO
NO OIL		-	-	-
THIRD ANGLE PROJECTION		TITLE Snap-On Bridle Ring Data-Cable Saddle Data Sheet		SIZE A4
		DWG NO. ZQxxSAD		REV A
		SCALE: 1:1	PRINT DATE	REFERENCES
				SHEET 1 OF 1

