

## 4-11/16" Square Single Gang Device Rings & Covers



**Material:** Galvanized Steel

**Application:** These one gang raised device covers are used to mount switches or receptacles on junction boxes for different finished-wall surface depths. Tapped 6-32 device mounting tabs accept switches devices and receptacles.

**Advantages:** Selection of various ring depths allow the installer to achieve a flush fit with the finished surface. The angled slots on the covers compensate for up to 12° of box misalignment on upright framing members.

**Field Names:** 4-11/16" plaster ring, 4-11/16" mud ring, 4-11/16" drywall ring, 5S device ring, 5S plaster ring, 5S mud ring, 11B plaster ring, 11B mud ring, 11B device ring, 11B device cover, 2100 raised device cover

**UL File No.:** E526989

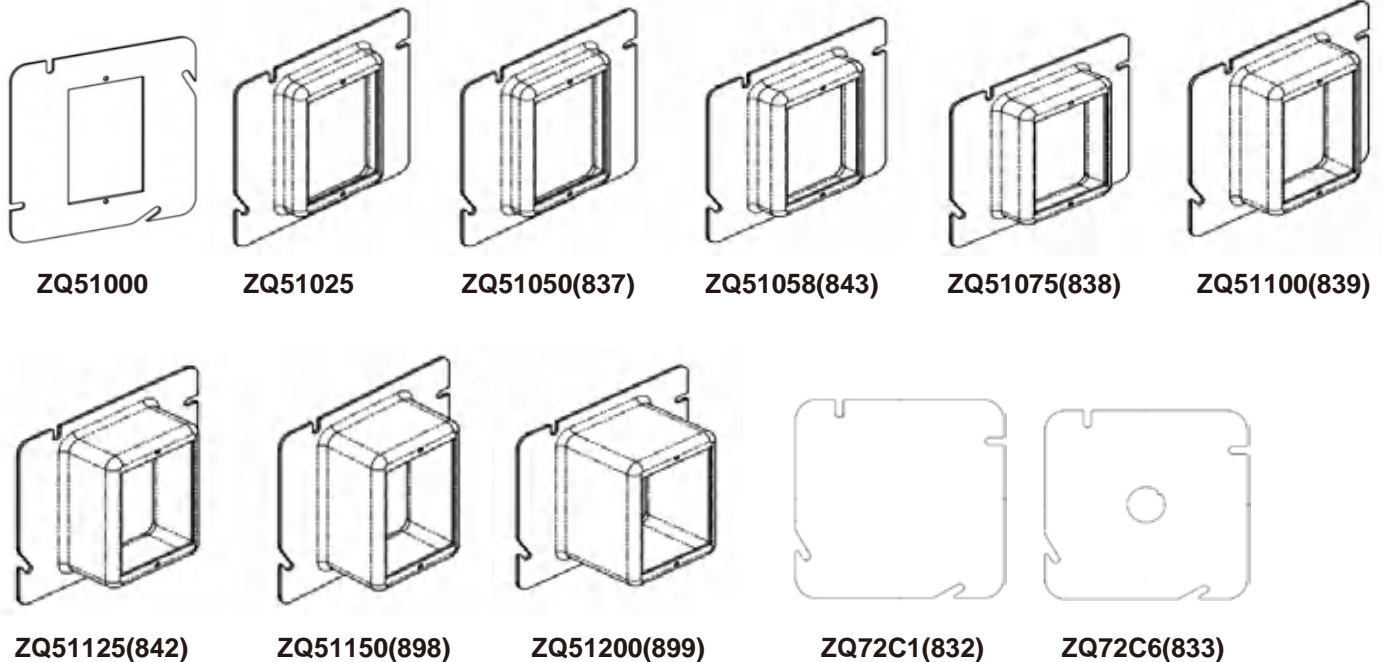

Catalog Number	Description	Depth	Cubic Inches	Ship Case	Weight/Case
<b>DEVICE RINGS</b>					
ZQ51000	Flat	---	---	50	14
ZQ51025	Raised 1/4"	1/4"	1.5	50	10
ZQ51050(837)	Raised 1/2"	1/2"	3.5	50	12
ZQ51058(843)	Raised 5/8"	5/8"	4.5	50	19
ZQ51075(838)	Raised 3/4"	3/4"	5.5	50	20
ZQ51100(839)	Raised 1"	1"	7.5	25	11
ZQ51125(842)	Raised 1-1/4"	1-1/4"	9.4	25	12
ZQ51150(898)	Raised 1-1/2"	1-1/2"	11.3	25	13
ZQ51200(899)	Raised 2"	2"	14.5	25	15
<b>COVERS</b>					
ZQ72C1(832)	Blank flat	Flat	---	50	21
ZQ72C6(833)	1/2" KO flat	Flat	---	50	21