

Catalog Number	B	C	Diameter(ΦA)	Cable capacity Cat 6/Cat 5e/Fiber Optic	Static Load(F)	Standard Box Quantity
ZQJH12	79.3 [3.12]	22.0 [0.87]	3/4"	10/16/16	60LBS	50
ZQJH21	107.3 [4.22]	34.1 [1.34]	1-5/16"	30/50/50	60LBS	50
ZQJH32	118.0 [4.65]	35.0 [1.38]	2"	50/80/80	60LBS	50
ZQJH64	178.0 [7.01]	49.0 [1.93]	4"	185/300/300	60LBS	25
ZQJH96	178.0 [7.01]	49.0 [1.93]	6"	230/450/450	60LBS	25

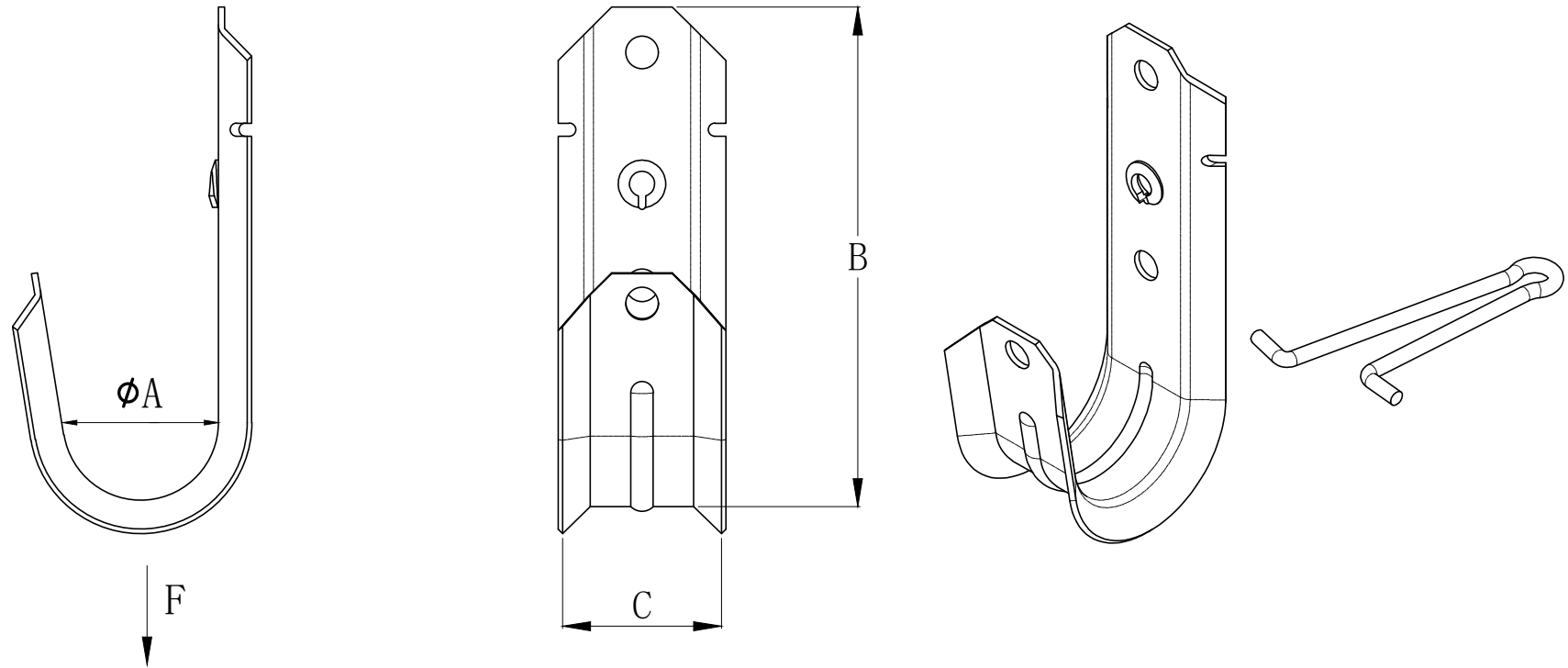

NOTES:

- 1. Material: Pre galvanized steel (G60) , Thickness: 1.20mm [0.047] .
- 2. Wire retainer available

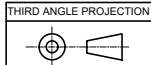

MATERIAL	Pre galvanized (G60)
FINISH	NO OIL

	NAME	DATE
DRAMN	YUAN	2022. 8. 17
CHECKED		
APPROVED (A)		
APPROVED (Customer)		

HZO Hangzhou Zhiqi Electrical co.,Ltd
TEL:86-571-82807601 Email:Linda@zhiqi-china.com
ELECTRIC

TITLE			
BASIC J HOOK			
SIZE	DWG NO.	REV	
A4	ZQJHxx		
SCALE: 1:1	PRINT DATE	REFERENCES	SHEET 1 OF 1

Catalog Number	B	C	ΦD	Diameter(ΦA)	Cable capacity Cat 6/Cat 5e/Fiber Optic	Static Load(F)	Standard Box Quantity
ZQJH12AC	79.3 [3.12]	22.0 [0.87]	1/4"	3/4"	10/16/16	60LBS	50
ZQJH21AC	107.3 [4.22]	34.1 [1.34]	1/4"	1-5/16"	30/50/50	60LBS	50
ZQJH32AC	118.0 [4.65]	35.0 [1.38]	1/4"	2"	50/80/80	60LBS	50
ZQJH64AC	178.0 [7.01]	49.0 [1.93]	1/4"	4"	185/300/300	60LBS	25
ZQJH96AC	178.0 [7.01]	49.0 [1.93]	1/4"	6"	230/450/450	60LBS	25

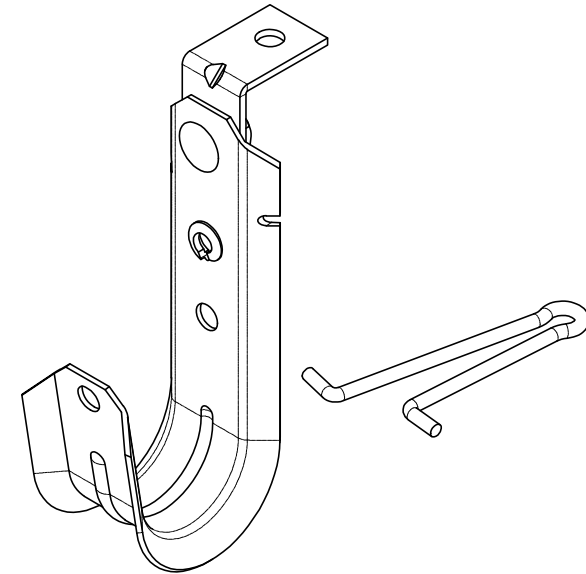
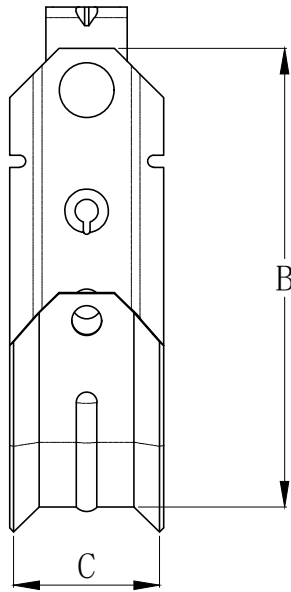
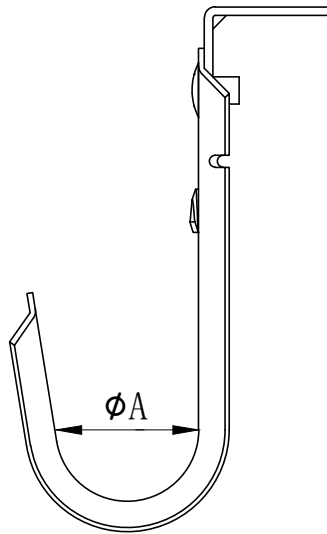
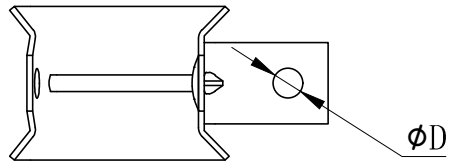

NOTES:

1. Material: J HOOK: Pre galvanized steel (G60) , Thickness: 1.20mm [0.047] .
Angle Bracket: Pre galvanized steel (G60) , Thickness: 2.0mm [0.079];
2. Wire retainer available

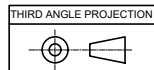

MATERIAL	Pre galvanized (G60)
FINISH	NO OIL

	NAME	DATE
DRAMN	YUAN	2022. 8. 17
CHECKED		
APPROVED (A)		
APPROVED (Customer)		

		Hangzhou Zhiqi Electrical co.,Ltd Tel:86-571-82807601 Email: Linda@zhiqi-china.com	
		TITLE	
J HOOK WITH 90 DEG ANGLE CLIP			
SIZE	DWG NO.	REV	
A4	ZQJHxxAC		
SCALE: 1:1	PRINT DATE	REFERENCES	SHEET 1 OF 1

Catalog Number	B	C	Diameter(Φ A)	Flange Thickness (FT)	Cable capacity Cat 6/Cat 5e/Fiber Optic	Static Load(F)	Standard Box Quantity
ZQJH12ACM24	79.3 [3.12]	22.0 [0.87]	3/4"	1/8"~1/4"	10/16/16	60LBS	50
ZQJH12ACM58	79.3 [3.12]	22.0 [0.87]	3/4"	5/16"~1/2"	10/16/16	60LBS	50
ZQJH12ACM912	79.3 [3.12]	22.0 [0.87]	3/4"	9/16"~3/4"	10/16/16	60LBS	50
ZQJH21ACM24	107.3 [4.22]	34.1 [1.34]	1-5/16"	1/8"~1/4"	30/50/50	60LBS	50
ZQJH21ACM58	107.3 [4.22]	34.1 [1.34]	1-5/16"	5/16"~1/2"	30/50/50	60LBS	50
ZQJH21ACM912	107.3 [4.22]	34.1 [1.34]	1-5/16"	9/16"~3/4"	30/50/50	60LBS	50
ZQJH32ACM24	118.0 [4.65]	35.0 [1.38]	2"	1/8"~1/4"	50/80/80	60LBS	50
ZQJH32ACM58	118.0 [4.65]	35.0 [1.38]	2"	5/16"~1/2"	50/80/80	60LBS	50
ZQJH32ACM912	118.0 [4.65]	35.0 [1.38]	2"	9/16"~3/4"	50/80/80	60LBS	50
ZQJH64ACM24	178.0 [7.01]	49.0 [1.93]	4"	1/8"~1/4"	185/300/300	60LBS	25
ZQJH64ACM58	178.0 [7.01]	49.0 [1.93]	4"	5/16"~1/2"	185/300/300	60LBS	25
ZQJH64ACM912	178.0 [7.01]	49.0 [1.93]	4"	9/16"~3/4"	185/300/300	60LBS	25
ZQJH96ACM24	178.0 [7.01]	49.0 [1.93]	6"	1/8"~1/4"	230/450/450	60LBS	25
ZQJH96ACM58	178.0 [7.01]	49.0 [1.93]	6"	5/16"~1/2"	230/450/450	60LBS	25
ZQJH96ACM912	178.0 [7.01]	49.0 [1.93]	6"	9/16"~3/4"	230/450/450	60LBS	25

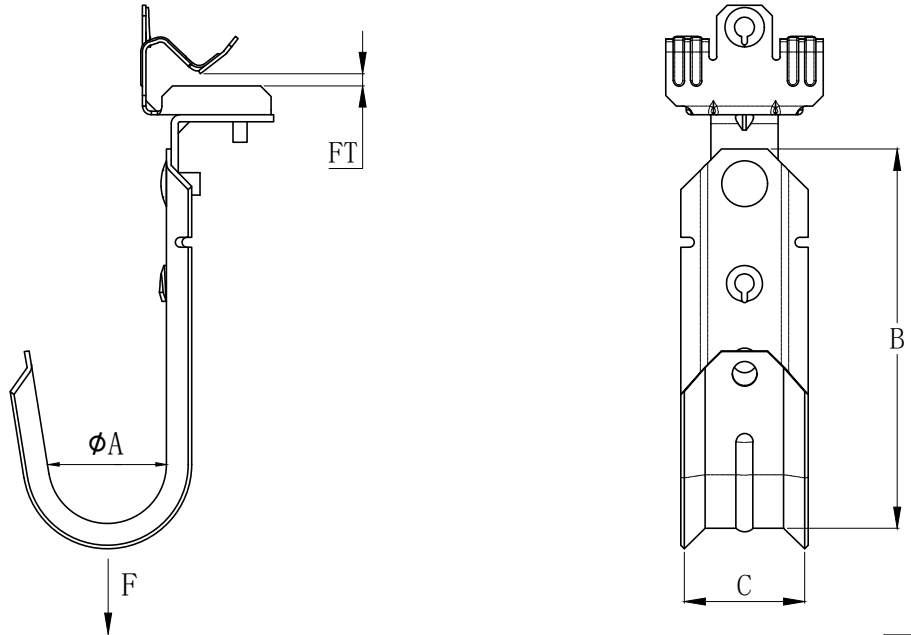
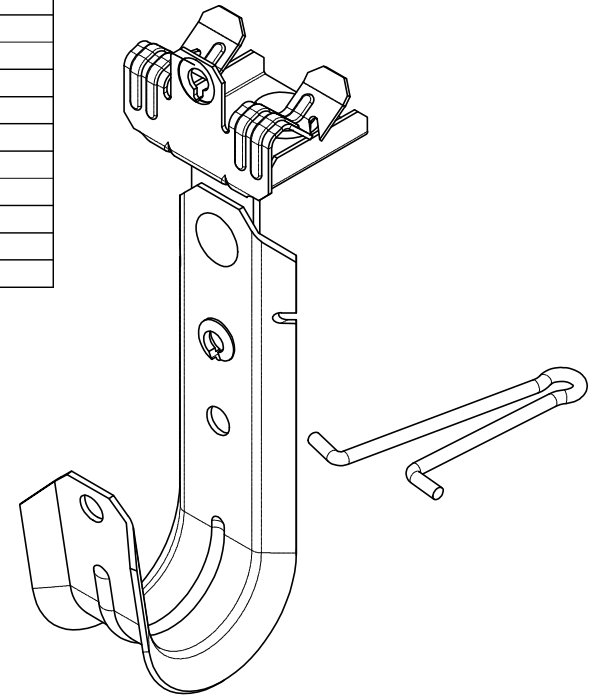

NOTES:

- 1. Material: J HOOK: Pre galvanized steel (G60) , Thickness: 1.20mm [0.047].
 Angle Bracket: Pre galvanized steel (G60) , Thickness: 2.0mm [0.079].
 Beam Clamp: C1065 steel , Thickness: 1.20mm [0.047]. Finish: Black E-coating
- 2. Wire retainer available

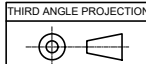

MATERIAL	Pre galvanized (G60)
FINISH	NO OIL

	NAME	DATE
DRAMN	YUAN	2022. 8. 17
CHECKED		
APPROVED (A)		
APPROVED (Customer)		

		Hangzhou Zhiqi Electrical co.,Ltd Tel:86-571-82807601 Email: Linda@zhiqi-china.com	
		TITLE J Hook with 360 Hammer on Beam clamp	
SIZE A4	DWG NO. ZQJHxxACMxx	REV	
SCALE: 1:1	PRINT DATE	REFERENCES	SHEET 1 OF 1

Catalog Number	B	C	D	Diameter(Φ A)	Cable capacity Cat 6/Cat 5e/Fiber Optic	Static Load(F)	Standard Box Quantity
ZQJH12ACPBC	79.3 [3.12]	22.0 [0.87]	14.9 [0.59]	3/4"	10/16/16	60LBS	50
ZQJH21ACPBC	107.3 [4.22]	34.1 [1.34]	14.9 [0.59]	1-5/16"	30/50/50	60LBS	50
ZQJH32ACPBC	118.0 [4.65]	35.0 [1.38]	14.9 [0.59]	2"	50/80/80	60LBS	50
ZQJH64ACPBC	178.0 [7.01]	49.0 [1.93]	14.9 [0.59]	4"	185/300/300	60LBS	25
ZQJH96ACPBC	178.0 [7.01]	49.0 [1.93]	14.9 [0.59]	6"	230/450/450	60LBS	25

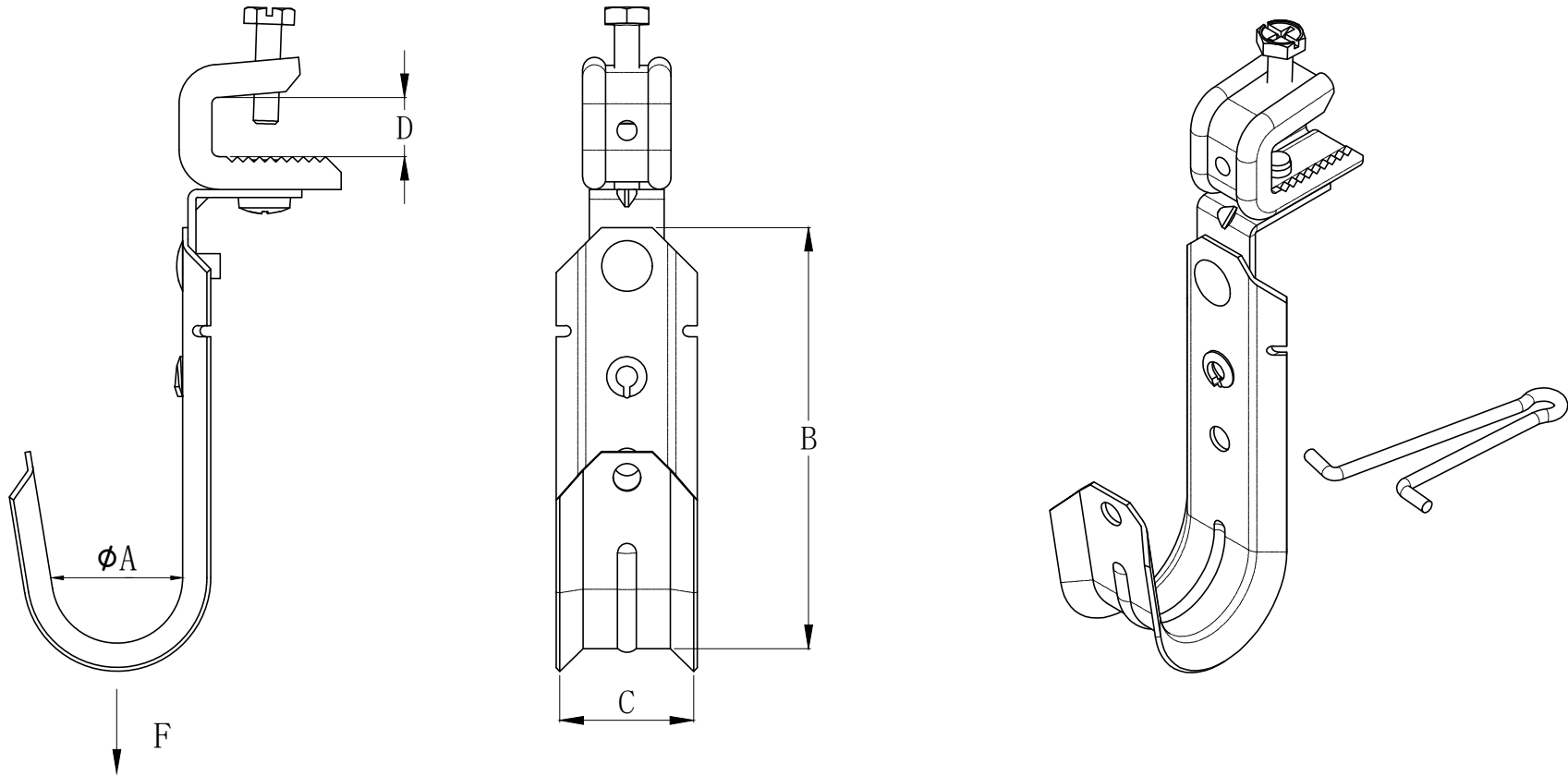

NOTES:

- Material: J HOOK: Pre galvanized steel (G60) , Thickness: 1.20mm [0.047] ;
Angle Bracket: Pre galvanized steel (G60) , Thickness: 2.0mm [0.079];
Beam Clamp: C.R.S, Thickness:2.0mm[0.079],Finish:Zinc plated ;
- Wire retainer available

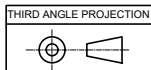

MATERIAL	Pre galvanized (G60)
FINISH	NO OIL

	NAME	DATE
DRAMN	YUAN	2022. 8. 17
CHECKED		
APPROVED (A)		
APPROVED (Customer)		

Hangzhou Zhiqi Electrical co.,Ltd
 Tel:86-571-82807601 Email: Linda@zhiqi-china.com

TITLE	
J HOOK WITH 360 DEG PRESSED BEAM CLAMP	

SIZE	DWG NO.	REV
A4	ZQJHxxACPBC	
SCALE: 1:1	PRINT DATE	REFERENCES
		SHEET 1 OF 1

Catalog Number	B	C	D	Diameter(Φ A)	Cable capacity Cat 6/Cat 5e/Fiber Optic	Static Load(F)	Standard Box Quantity
ZQJH12ACSSBC	79.3 [3.12]	22.0 [0.87]	18.3 [0.72]	3/4"	10/16/16	60LBS	50
ZQJH21ACSSBC	107.3 [4.22]	34.1 [1.34]	18.3 [0.72]	1-5/16"	30/50/50	60LBS	50
ZQJH32ACSSBC	118.0 [4.65]	35.0 [1.38]	18.3 [0.72]	2"	50/80/80	60LBS	50
ZQJH64ACSSBC	178.0 [7.01]	49.0 [1.93]	18.3 [0.72]	4"	185/300/300	60LBS	25
ZQJH96ACSSBC	178.0 [7.01]	49.0 [1.93]	18.3 [0.72]	6"	230/450/450	60LBS	25

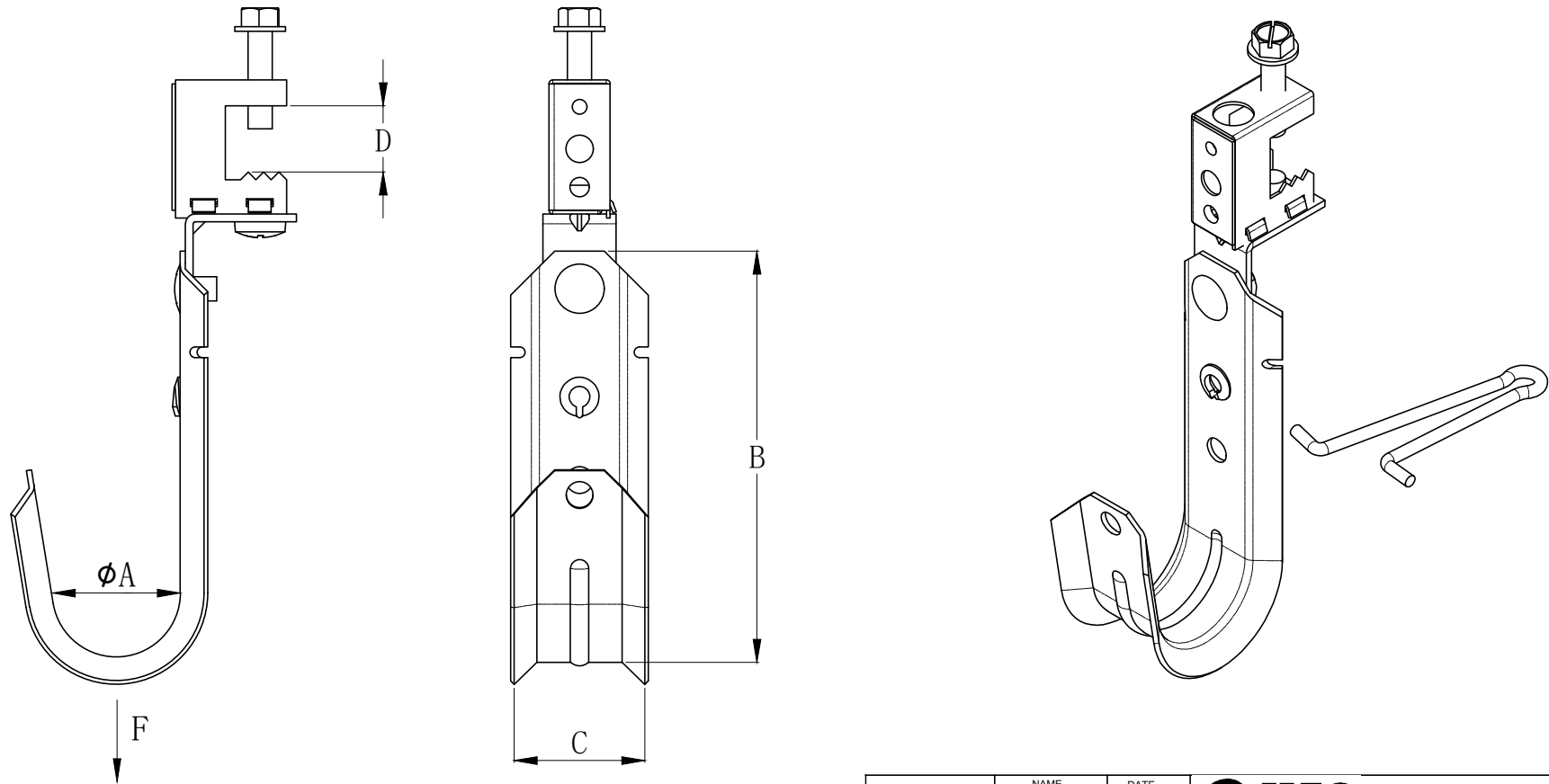

NOTES:

- Material: J HOOK: Pre galvanized steel (G60) , Thickness: 1.20mm [0.047] ;
 Angle Bracket: Pre galvanized steel (G60) , Thickness: 2.0mm [0.079];
 Beam Clamp: C1065 steel, Thickness: 0.8mm [0.031]. Finisi:Black E-coating.
- Wire retainer available.

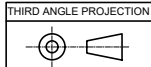

MATERIAL	Pre galvanized (G60)
FINISH	NO OIL

	NAME	DATE
DRAMN	YUAN	2022. 8. 17
CHECKED		
APPROVED (A)		
APPROVED (Customer)		

 Hangzhou Zhiqi Electrical co.,Ltd Tel:86-571-82807601 Email: Linda@zhiqi-china.com		TITLE
		J HOOK WITH 360 DEG STAMPED STEEL BEAM CLAMP
SIZE	DWG NO.	REV
A4	ZQJHxxACSSBC	
SCALE: 1:1	PRINT DATE	REFERENCES
		SHEET 1 OF 1

Catalog Number	B	C	Diameter(Φ A)	Flange Thickness (FT)	Cable capacity Cat 6/Cat 5e/Fiber Optic	Static Load(F)	Standard Box Quantity
ZQJH12HOK-24	79.3 [3.12]	22.0 [0.87]	3/4"	1/8"-1/4"	10/16/16	60LBS	50
ZQJH12HOK-58	79.3 [3.12]	22.0 [0.87]	3/4"	5/16"-1/2"	10/16/16	60LBS	50
ZQJH12HOK-912	79.3 [3.12]	22.0 [0.87]	3/4"	9/16"-3/4"	10/16/16	60LBS	50
ZQJH21HOK-24	107.3 [4.22]	34.1 [1.34]	1-5/16"	1/8"-1/4"	30/50/50	60LBS	50
ZQJH21HOK-58	107.3 [4.22]	34.1 [1.34]	1-5/16"	5/16"-1/2"	30/50/50	60LBS	50
ZQJH21HOK-912	107.3 [4.22]	34.1 [1.34]	1-5/16"	9/16"-3/4"	30/50/50	60LBS	50
ZQJH32HOK-24	118.0 [4.65]	35.0 [1.38]	2"	1/8"-1/4"	50/80/80	60LBS	50
ZQJH32HOK-58	118.0 [4.65]	35.0 [1.38]	2"	5/16"-1/2"	50/80/80	60LBS	50
ZQJH32HOK-912	118.0 [4.65]	35.0 [1.38]	2"	9/16"-3/4"	50/80/80	60LBS	50
ZQJH64HOK-24	178.0 [7.01]	49.0 [1.93]	4"	1/8"-1/4"	185/300/300	60LBS	25
ZQJH64HOK-58	178.0 [7.01]	49.0 [1.93]	4"	5/16"-1/2"	185/300/300	60LBS	25
ZQJH64HOK-912	178.0 [7.01]	49.0 [1.93]	4"	9/16"-3/4"	185/300/300	60LBS	25
ZQJH96HOK-24	178.0 [7.01]	49.0 [1.93]	6"	1/8"-1/4"	230/450/450	60LBS	25
ZQJH96HOK-58	178.0 [7.01]	49.0 [1.93]	6"	5/16"-1/2"	230/450/450	60LBS	25
ZQJH96HOK-912	178.0 [7.01]	49.0 [1.93]	6"	9/16"-3/4"	230/450/450	60LBS	25

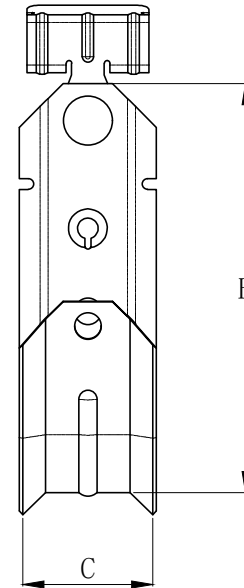
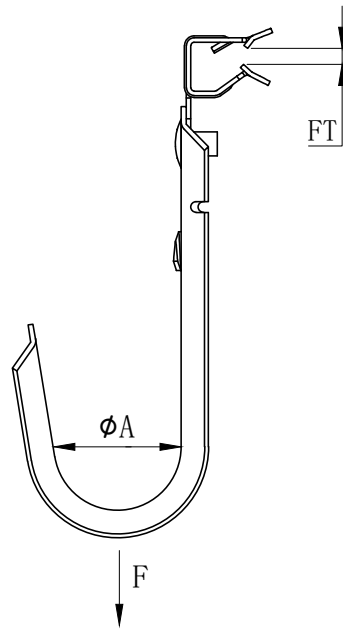
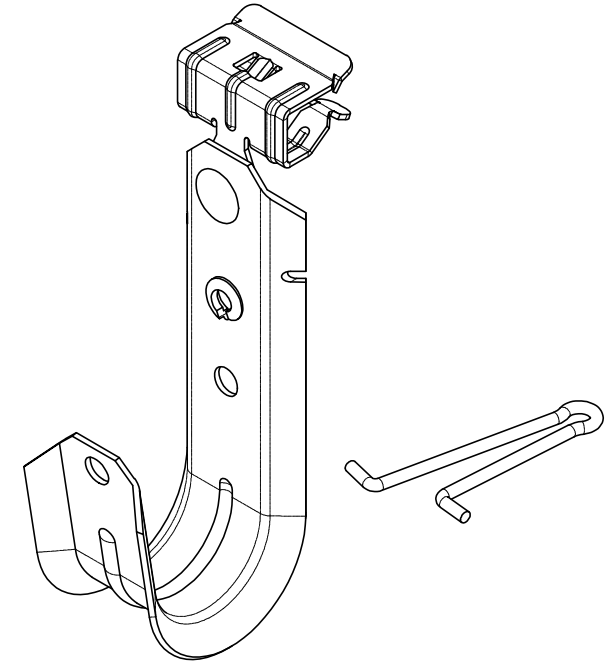

NOTES:

- Material: J HOOK: Pre galvanized steel (G60) , Thickness: 1.20mm [0.047] .
Beam Clamp: C1065 steel , Thickness: 1.2mm [0.047].Finish: Black E-coating
- Wire retainer available

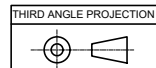

MATERIAL	Pre galvanized (G60)
FINISH	NO OIL

	NAME	DATE
DRAMN	YUAN	2022. 8. 17
CHECKED		
APPROVED (A)		
APPROVED (Customer)		

		Hangzhou Zhiqi Electrical co.,Ltd Tel:86-571-82807601 Email: Linda@zhiqi-china.com	
		TITLE	
J Hook with side Hammer on beam clamp			
SIZE	DWG NO.	REV	
A4	ZQJHxxHOK-xx		
SCALE: 1:1	PRINT DATE	REFERENCES	SHEET 1 OF 1

Catalog Number	B	C	D	Diameter(Φ A)	Cable capacity Cat 6/Cat 5e/Fiber Optic	Static Load(F)	Standard Box Quantity
ZQJH12PBC	79.3 [3.12]	22.0 [0.87]	14.9 [0.59]	3/4"	10/16/16	60LBS	50
ZQJH21PBC	107.3 [4.22]	34.1 [1.34]	14.9 [0.59]	1-5/16"	30/50/50	60LBS	50
ZQJH32PBC	118.0 [4.65]	35.0 [1.38]	14.9 [0.59]	2"	50/80/80	60LBS	50
ZQJH64PBC	178.0 [7.01]	49.0 [1.93]	14.9 [0.59]	4"	185/300/300	60LBS	25
ZQJH96PBC	178.0 [7.01]	49.0 [1.93]	14.9 [0.59]	6"	230/450/450	60LBS	25

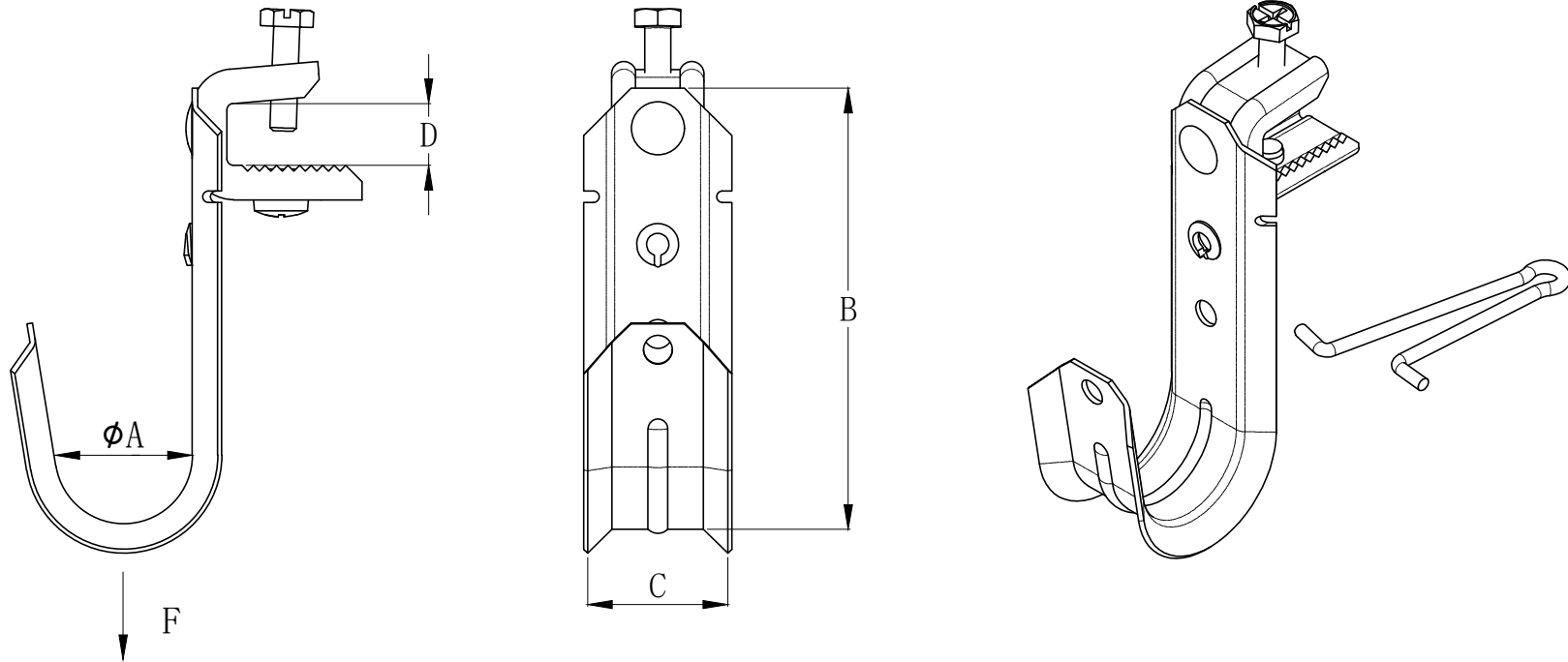

NOTES:

- Material: J HOOK: Pre galvanized steel (G60) , Thickness: 1.20mm [0.047] ;
Beam Clamp: C.R.S, Thickness:2.0mm[0.079],Finish:Zinc plated ;
- Wire retainer available;

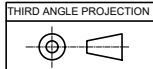

MATERIAL	Pre galvanized (G60)
FINISH	NO OIL

	NAME	DATE
DRAMN	YUAN	2022. 8. 17
CHECKED		
APPROVED (A)		
APPROVED (Customer)		

		Hangzhou Zhiqi Electrical co.,Ltd Tel:86-571-82807601 Email: Linda@zhiqi-china.com	
		TITLE J HOOK WITH PRESSED BEAM CLAMP	
SIZE	DWG NO.	REV	
A4	ZQJHxxPBC		
SCALE: 1:1	PRINT DATE	REFERENCES	SHEET 1 OF 1

Catalog Number	B	C	D	Diameter(ΦA)	Cable capacity Cat 6/Cat 5e/Fiber Optic	Static Load(F)	Standard Box Quantity
ZQJH12SSBC	79.3 [3.12]	22.0 [0.87]	18.3 [0.72]	3/4"	10/16/16	60LBS	50
ZQJH21SSBC	107.3 [4.22]	34.1 [1.34]	18.3 [0.72]	1-5/16"	30/50/50	60LBS	50
ZQJH32SSBC	118.0 [4.65]	35.0 [1.38]	18.3 [0.72]	2"	50/80/80	60LBS	50
ZQJH64SSBC	178.0 [7.01]	49.0 [1.93]	18.3 [0.72]	4"	185/300/300	60LBS	25
ZQJH96SSBC	178.0 [7.01]	49.0 [1.93]	18.3 [0.72]	6"	230/450/450	60LBS	25

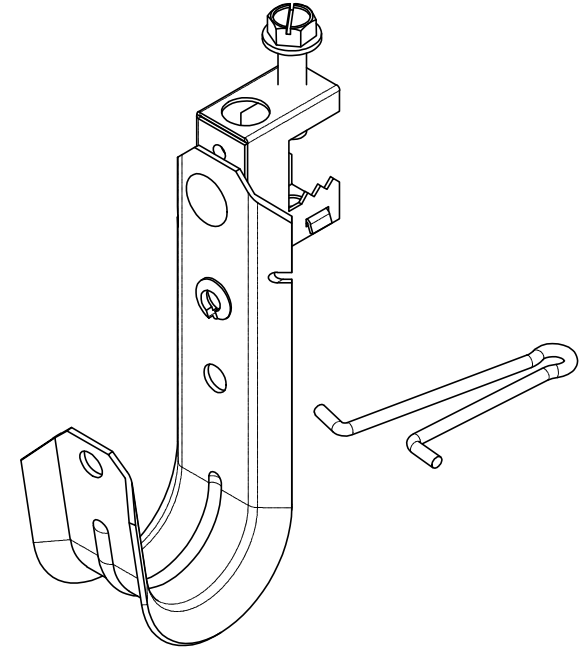
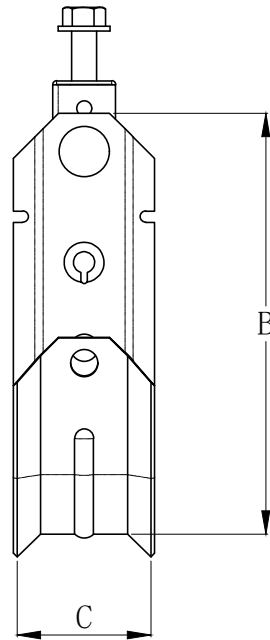
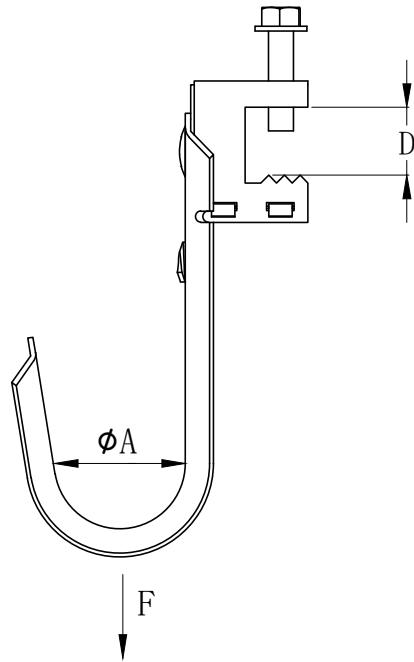

NOTES:

1. Material: J HOOK: Pre galvanized steel (G60) , Thickness: 1.20mm [0.047] .
Beam Clamp: C1065 steel, Thickness: 0.8mm [0.031]. Finish: Black E-coating
2. Wire retainer available

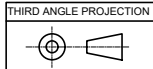

MATERIAL	Pre galvanized (G60)
FINISH	NO OIL

	NAME	DATE
DRAMN	YUAN	2022. 8. 17
CHECKED		
APPROVED (A)		
APPROVED (Customer)		

		Hangzhou Zhiqi Electrical co.,Ltd <small>Tel:86-571-82807601 Email: Linda@zhiqi-china.com</small>	
		TITLE J HOOK WITH STAMPED STEEL BEAM CLAMP	
SIZE	DWG NO.	REV	
A4	ZQJHxxSSBC		
SCALE: 1:1	PRINT DATE	REFERENCES	SHEET 1 OF 1

Catalog Number	B	C	Rod Size(RS)	Diameter(Φ A)	Cable capacity Cat 6/Cat 5e/Fiber Optic	Static Load(F)	Standard Box Quantity
ZQJH12W	79.3 [3.12]	22.0 [0.87]	1/4"	3/4"	10/16/16	60LBS	50
ZQJH21W	107.3 [4.22]	34.1 [1.34]	1/4"	1-5/16"	30/50/50	60LBS	50
ZQJH32W	118.0 [4.65]	35.0 [1.38]	1/4"	2"	50/80/80	60LBS	50
ZQJH64W	178.0 [7.01]	49.0 [1.93]	1/4"	4"	185/300/300	60LBS	25
ZQJH96W	178.0 [7.01]	49.0 [1.93]	1/4"	6"	230/450/450	60LBS	25

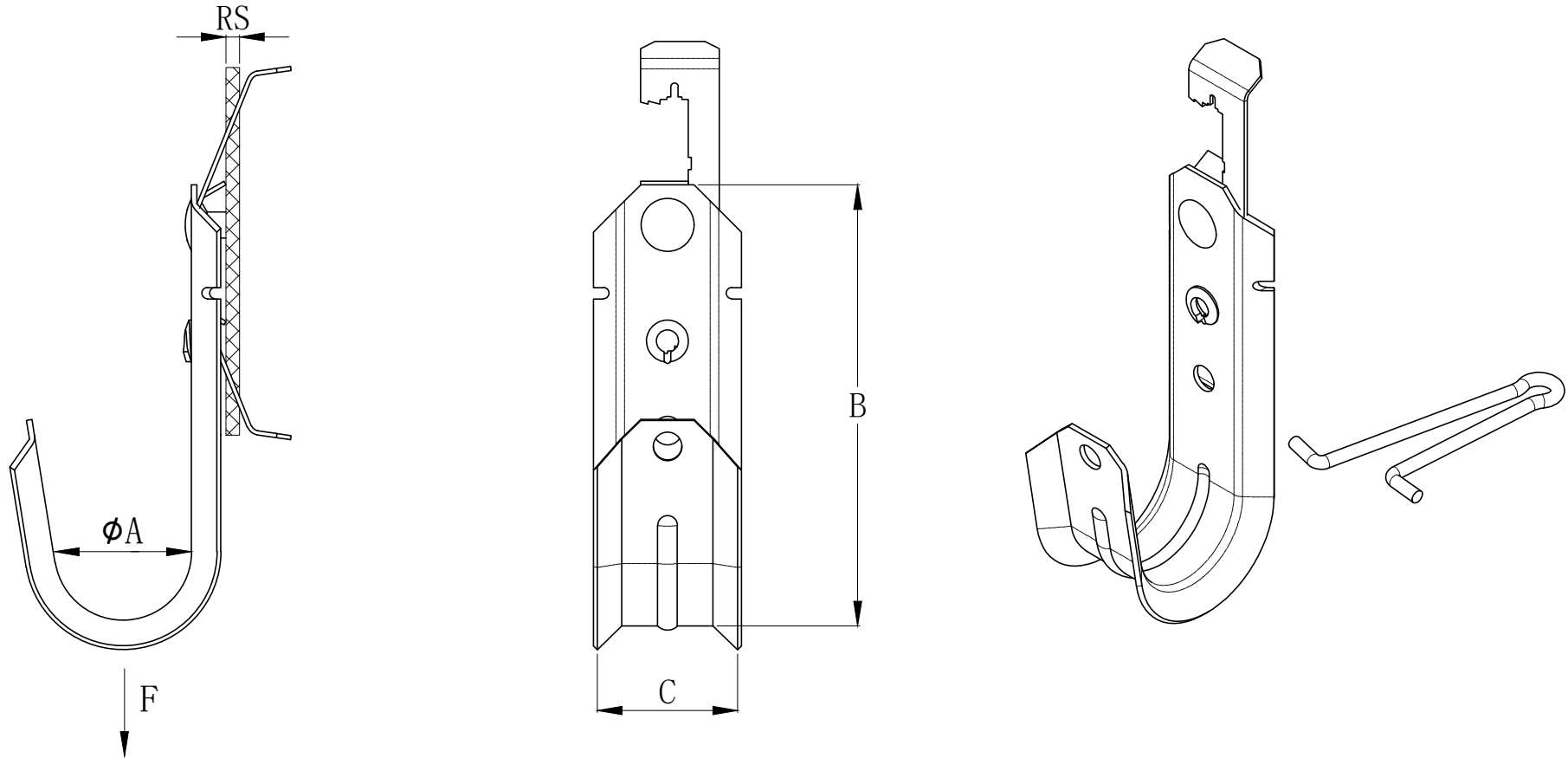

NOTES:
 1. Material: J HOOK: Pre galvanized steel (G60) , Thickness: 1.20mm [0.047] .
 Bat Wing: C1065 steel .Thickness:1.00mm[0.039],Finish: Black E-coating;
 2. Wire retainer available

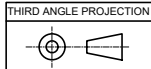

MATERIAL	Pre galvanized (G60)
FINISH	NO OIL

	NAME	DATE
DRAMN	YUAN	2022. 8. 17
CHECKED		
APPROVED (A)		
APPROVED (Customer)		

Hangzhou Zhiqi Electrical co.,Ltd Tel:86-571-82807601 Email: Linda@zhiqi-china.com		TITLE	
		J HOOK WITH BATWING	
SIZE	DWG NO.	REV	
A4	ZQJHxxW		
SCALE: 1:1	PRINT DATE	REFERENCES	SHEET 1 OF 1